

Department of Distance and Continuing Education

University of Delhi

दूरस्थ एवं सतत् शिक्षा विभाग

दिल्ली विश्वविद्यालय



B.A.(Hons.) Economics-(DSC-1) /

B.A. (Programme)-Minor Paper :

(Paper-II Discipline-A₁/Paper-III Discipline B₁)

Semester-I

Course Credit-4

INTRODUCTORY MICROECONOMICS

(Department of Economics)

As per the UGCF - 2022 and National Education Policy 2020



————— *Editorial Board* —————

Prof. J. Khuntia, Bhawna Pandey

Dr. Anand Kumar, Devender

————— *Content Writers* —————

***Sugandh Kumar Choudhary, Tasha Agarwal,
Parul Jain, Taramati, Devender, Pallavi Khanna,
Suramaya Sharma, Divya Dua***

————— *Academic Coordinator* —————

Deekshant Awasthi

© Department of Distance and Continuing Education

ISBN : 978-93-95774-80-2

1st edition: 2022

E-mail: ddceprinting@col.du.ac.in
economics@col.du.ac.in

Published by:

Department of Distance and Continuing Education under
the aegis of Campus of Open Learning/School of Open Learning,
University of Delhi, Delhi-110 007

Printed by:

School of Open Learning, University of Delhi



Introductory Microeconomics

- Corrections/Modifications/Suggestions proposed by Statutory Body, DU/Stakeholder/s in the Self Learning Material (SLM) will be incorporated in the next edition. However, these corrections/modifications/suggestions will be uploaded on the website <https://sol.du.ac.in>. Any feedback or suggestions can be sent to the email- feedbackslm@col.du.ac.in



INTRODUCTORY MICROECONOMICS
Study Material : Lesson 1-12

TABLE OF CONTENTS

	Name of Lesson	Content Writers	Page No
LESSON 1	Resources and Opportunities	Sugandh Kumar Choudhary	1-15
LESSON 2	Gains from Trade	Tasha Agarwal	16-23
LESSON 3	Individual and Society	Sugandh Kumar Choudhary	24-32
LESSON 4	Demand and Supply	Tasha Agarwal	33-53
LESSON 5	Elasticity of Demand and Supply	Tasha Agarwal	54-72
LESSON 6	Price and Resource Allocation	Tasha Agarwal	73-87
LESSON 7	Trade & Welfare	Parul Jain	88-101
LESSON 8	Taxation	Taramati	102-113
LESSON 9	Public Good	Devender	114-121
LESSON 10	Poverty and Inequality	Pallavi Khanna	122-154
LESSON 11	Individual Decision	Suramya Sharma and Divya Dua	155-172
LESSON 12	Individual Strategic Interactions	Suramya Sharma and Divya Dua	173-190

About Contributors

Contributor's Name	Designation
Sugandh Kumar Choudhary	Assistant Professor, Department of Economics, S.S.Khanna Girl's Degree College, University of Allahabad
Tasha Agarwal	Ph.D. Scholar, Ambedkar University, Delhi
Parul Jain	Assistant Professor, Sri Aurobindo College, University of Delhi, Delhi
Taramati	Guest Faculty, Kirori Mal College, University of Delhi, Delhi



Introductory Microeconomics

Devender	Assistant Professor, Department of Distance and Continuing Education, University of Delhi, Delhi
Pallavi Khanna	Research Scholar, Department of Economics, Jamia Millia Islamia, Delhi
Suramya Sharma	Guest Faculty, NCWEB, Hansraj College, University of Delhi
Divya Dua	Guest Faculty, NCWEB, Sri Guru Gobind Singh College of Commerce, University of Delhi, Delhi



LESSON 1

RESOURCES AND OPPORTUNITIES

STRUCTURE

- 1.1 Learning Objectives
- 1.2 Introduction
- 1.3 What are Resources
 - 1.3.1 Economic Resources and their Importance
 - 1.3.2 What are economic agents
- 1.4 Central Problems of an Economy
 - 1.4.1 What to Produce
 - 1.4.2 How to Produce
 - 1.4.3 For Whom to Produce
- 1.5 Production Possibility Frontier
 - 1.5.1 Opportunity Cost
 - 1.5.2 Sunk Cost
- 1.6 Summary
- 1.7 Glossary
- 1.8 Answers to In-Text Questions
- 1.9 Self-Assessment Questions
- 1.10 References
- 1.11 Suggested Readings

1.1 Learning Objectives

The objective of this chapter is to understand different type of resources in an economy and learn about the tools for maximising the utilisation of opportunities in a resource constraint economy. There are times when resources constraint arises due to mismatch between supply and demand. This chapter will enable students to understand:

1. Different type of resources



2. Central problems of an economy
3. Trade-off between the production of two goods in the form of rate of transformation and
4. Production possibility frontier

1.2 INTRODUCTION

The growth and developmental aspiration of a country are fuelled by the resources it has. However, as we all know, resources are limited and relatively scarce, but human wants are never-ending. The development, desire, and prosperity of a country are limited by its resource endowment. Given its limited resources and unlimited growth aspirations, judicious resource distribution becomes imperative for a country's progress. It becomes all the more important to realize optimal utilization of resources. Against this backdrop, the chapter deals with the understanding of the availability of resources and exploration of economic opportunities in an economy to attain the full potential of an aspirational country.

1.3 WHAT ARE RESOURCES

Maximum utilisation of resources is most significant objective for understanding the central problems of an economy. The term “resource” is a broad term, but the common definition of resource is that these are goods or services that can be utilised to produce goods and services to be consumed by people. In economics, resources are classified into four categories – labour, capital, land and entrepreneurship.

Your thought on this

Do you use social media? If yes, how much screen time do you spend on Facebook and Twitter daily? Pradyumn uses Facebook for 3 hours a day, whereas Shalini does not have an account on Facebook. She utilizes her time reading economics and exercising during her free time. Indicate whether the following statements are true or false.

- Time is an unlimited resource
- Pradyumn makes more judicious use of his time.
- There are alternative use of time and indirect costs involved.
- Shalini is missing the opportunities that may arise from professional networking via social media



Do you realise that every choice you make, there are costs involved and benefits attached. Can you think of costs involved with prolonged usage of social media? How can you quantify the true cost of using social media? Discuss among your friends and list them out.

Time management is an important aspect of student life because time is a limited resource. How you make the best use of your limited resource marks the beginning of learning economics as a subject in your student life.

Important points need to be focused upon to understand resource constraints in an economy.

- i. The scarcity of resources can be understood as a mismatch between supply and demand. When demand exceeds supply, we have the problem of scarcity as resources are limited.
- ii. Economics is the study of decisions and choices made for the allocation of resources among competing needs in order to satisfy as many wants as possible. How choices are made affect society. It is an important part of Economics.
- iii. Choices are made on the basis of priorities.

Activity 1

You are invited to a birthday party with your friend. There are so many delicacies being served at the party, and you must decide how to fill your plate as there are many of your favourite items. Identify the trade-off you see and the difficult choices you have to make. Do you experience any scarcity of resources in terms of your capacity to eat? Make a group of your classmates and discuss whether the choice involves elements of scarcity.

People, government and decision makers always try to optimize. We all choose the best among available alternatives. **This is the first basic principle of economics.** We all love to be in equilibrium. Equilibrium is nothing but a state of being where one would not like to change their behaviour. **This is the second principle of economics.** Simply said, equilibrium is a state of existence when you do not have any incentive to move away from your choices at equilibrium.

1.3.1 Economic Resources and their Importance

You see many goods and services available around you. A number of inputs must have gone into producing these goods and services. Critical factors that go into production are called economic resources. As these factors are scarce, their efficient allocation toward the production of goods and services must be judiciously made. Economics deals with the study



of allocation of scarce resources in a systematic coordinated manner as every scarce resource has an alternative use. By studying economics, you learn how to make the optimal utilisation of these resources to achieve maximum satisfaction or utility. To begin with, important resources that decide the economy's path are **Land, Labour, Capital and Entrepreneurship**. Capital can be further classified into fixed capital and variable capital. Fixed capital cannot be changed in the short run. Can you think of other resources that are important for the economy? Does raw material qualify as an economic resource?

A perspective

As per Economic Survey – 2021-22, health expenditure increased by 73% from pre – COVID – 2019 level. To put into perspective, India increased its health expenditure from Rs. 2.73 lakh crore in 2019 – 20 to Rs. 4.72 lakh crore in 2021 – 22 (budget estimate). Do you think the massive additional expenditure of Rs. 2 lakh crores could have been used for employment generation or capacity building in the economy had the pandemic not struck humanity? The cost of India's Mars Mission in 2016 was Rs. 450 crores. With Rs. 2 lakh crore funds, how many times could India have launched the Mars mission? Let us keep the inflation level constant.

1.3.2 What are Economic Agents

Every individual or group who makes choices are the agent of the economy. Do you choose between healthy food cooked by your mother and random fast food on your way home? Have you ever chosen between bunking your economic class or going to a movie hall to watch your favourite actor? With family as a unit, all members have unanimously decided on a vacation to a hill station. The family could have also visited other places, but they decided that a hill station was the choice they made among numerous available vacation alternatives. Every choice you make has consequences for the economy and resources, and therefore, rightly called agents of the economy.

Activity 2

Make a logical story by arranging the following statements.

- Your monthly pocket money is a resource
- You have numerous wants to satisfy from your limited resource
- You choose to spend your pocket money on books rather than a visit to India gate



would be appreciated by your parents

- The paper industry gets an impetus from the choice you have made
- The choice you have made gives signal to the economy.

IN-TEXT QUESTIONS

1. The most abundant factor of production in India is _____.
2. _____ capital cannot be changed in the short run.
3. _____ capital can be changed in the short run.
4. Scarcity arises when _____ exceeds _____.
5. Effort to raise finance for implementing an innovative idea is **not** an economic resource (True/False)

1.4 CENTRAL PROBLEMS OF AN ECONOMY

Resource constrained economy must address certain issues or fundamental problems within its socio – economic framework that could help the economy grow and take the most suitable growth path commensurate with its resources and objectives. It is important to understand why economic problems arise. Economic problems arise mainly due to three points as mentioned below:

a) Society has unlimited demand

An individual's demand is not only limited to fulfilling their basic needs for survival. Beyond basic need, people demand items that satisfy their desire, and this list is endless.

b) Economy has limited resources

With limited pocket money, you often face trade-off between prioritising one over the other. As your pocket money have competing utility, you have to fulfil your desires with limited resource. Similarly. A country faces the problem of maximising society's utility with limited resources.

c) There are competing or alternative uses of resources that need to be judiciously used

Each raw material and resource can be used for various other purposes. For example, once you purchase something (say books) with your available pocket money, you may



not be able to go to a movie. You must decide your priority and make the best use of the available resource.

Based on the above, three central problems of an economy are:

1.4.1 What to produce and in what quantity?

The above question of what to produce and what quantity is often faced by decision-makers. Resources like land, labour, capital, and raw materials are scarce in the economy, which limits the fulfilment of every demand. It, therefore, becomes important to prioritize what to produce and in what quantity. For example, a farmer has a fixed area of land for cultivation. Here the land is a limited resource. He cannot produce everything on the same piece of land simultaneously. He must decide what to produce on the given piece of land. If he decides to produce rice, he cannot produce pulses on the same land simultaneously. Now, having decided on rice over pulses, now he must decide how much rice he wants to produce. This is the second aspect of the problem. This problem can be solved by allocating resources and prioritizing one output over the other so that society's aggregate satisfaction can be maximized. A country cannot produce everything under the sun. Like you must decide what you want to become, a country must decide what it needs to produce and what need not be produced. An economy must decide whether it needs to prioritize the production of consumer goods over producer goods or vice-versa. The economy must also decide the extent to which luxury goods should be produced compared to goods of basic necessity. If good X is produced in the economy, then resources must be shifted towards goods X to an extent, and these resources cannot be made available to produce good Y simultaneously. It's a trade-off between the production of good X and good Y, which can be better explained using the **Production Possibility Frontier (PPF)**. It will be introduced later in the chapter.

1.4.2 How to produce?

The problem of 'how to produce' is about the choice of technique related to production. Choice of technique is basically about the combination of different factors of production that can be used to produce a good. Techniques of production determine the exact proportion of factor inputs that must be utilised in the production of goods. The techniques can be either labour intensive or capital intensive. Labour-intensive techniques use more labour and less capital, whereas capital-intensive techniques of production use more capital and less labour. The decision to adopt a particular technique of production depends upon two things:

- a. The relative price of labour and capital, and
- b. The relative efficiency of the two inputs



Let us suppose you have decided to become a doctor. You must streamline your books, study hours, and coaching. You must reduce your screen time on social media. To gain satisfaction from being a doctor in the future, you must sacrifice your social media screen time and devote your balance time to your studies. Similarly, if an economy decides to produce good X, it must chalk out how much land, labor, capital, etc., should be dedicated to the production process. Once decided, these factors of production cannot be used for producing any other good simultaneously. The choice of production technique depends upon its availability and the comparative cost of the available production technique.

1.4.3 For whom to produce?

Another problem that an economy faces is for whom to produce. The underlying question is related to the compensation to different factors of production (land, labour, capital, and entrepreneurship). For example, the entrepreneur who has started a restaurant business, must pay for the various factors of production. He must pay wages to cook, rent to the owner of the building, and salary to himself for running the business as an entrepreneur. The income, thus generated, is further used to satisfy various wants of individuals involved in the production process.

For example, it may not be difficult for your mother to cook your favourite dish. She must consider two things – firstly, your taste which is manifested in your demand, and secondly, the availability of resources at home, which reflects the supply side of economics. The national economy also works on a similar pattern of demand and supply of individuals that make up a society. Higher demand is reflected commensurately in the price of the productive resource. The owner of productive resources has to be compensated with a higher price as determined by the invisible hand of the market, which plays through market forces of demand and supply.

Case study

India has an abundant labor supply, with about 900 million people (67% of the total population) in the working age group of 15 – 64. As per the report from the Confederation of Indian Industry (CII), if the country's working-age population — which is expected to increase by over 100 million people between 2020-30, is productively employed, India's GDP can grow from the current \$3 trillion to \$9 trillion by 2030, and \$47 trillion by 2047. Despite the rising literacy rate, the employability of workers is a big challenge due to the skill gap in the workforce. In this background, form a group and debate the following:



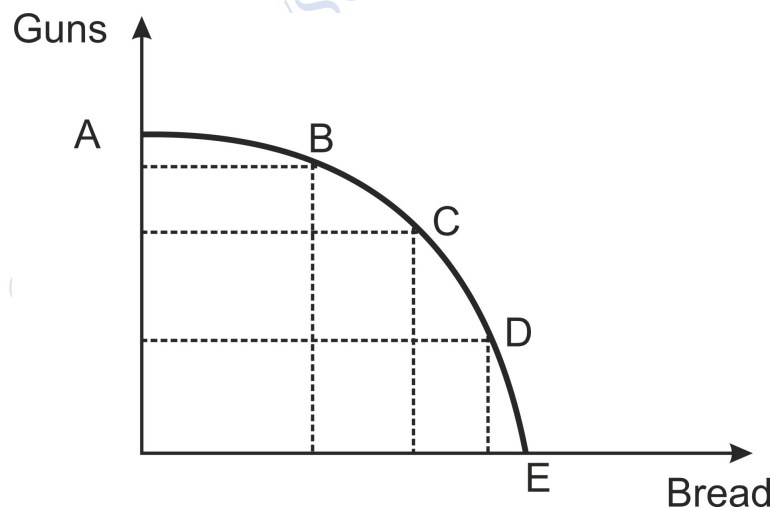
- a. Major employability issue plaguing Indian workforce
- b. What measures would you suggest filling the skill gap in the workforce?
- c. Analyse the role of Pradhan Mantri YuvaUdyamita Vikas Abhiyan in productive employment generation for labour resources in the economy.

IN – TEXT QUESTIONS

- 6. Who are economic agents?
- 7. What are the two principles of economics?
- 8. Central problems of an economy mainly refer to _____

1.5 PRODUCTION POSSIBILITY FRONTIER (PPF)

The production possibility frontier (PPF) reflects the mix of combinations of two goods that can be produced with the given quantity of capital and labour. It is a curve that shows the maximum quantity of good X that can be produced for a given production level of another good, say good Y, with the given level of capital and labour in the economy. A typical production possibility frontier is given below:



Curve ABCDE is the production possibility frontier. The curve is concave to the origin and downward sloping from left to right. The concavity of PPF shows that the curve has an increasing slope. The slope of the curve indicates an increasing **Marginal Rate of Transformation (MRT)**.



The marginal rate of transformation is nothing but the quantity of good Y that must be given up for producing one additional unit of good X. It must be noted that the technology of production is assumed to be fixed. In the above graph, MRT can be defined as the quantity of production of guns that must be foregone to produce one additional unit of bread.

Now, let us understand various points on the PPF. Beginning with point X in the graph, it reflects that all available resources, namely capital, and labour, are not efficiently utilised. Therefore, point X represents the underproduction of both the goods – guns and bread. Reaching point B is obviously desirable, where capital and labour are fully and efficiently utilised. Point Y is desirable because, this point shows higher level of both the goods – guns and bread. But this point is not achievable due to the limited availability of factor resources. Point B, C, and D represents different combinations of guns and bread that can be produced with available capital and labour in the economy. Similarly, all points on the PPF shows efficient production level. As one moves from B to C and then to D, production of guns falls but production of bread rises. The downward sloping PPC shows exactly the phenomenon that as the production of one commodity increases, the production of another commodity must be reduced.

Important **assumptions** of the production possibility frontier are:

- 1) Only two goods are produced in the economy. In the graph above, only guns and bread are produced.
- 2) The state of technology and other productive resources of the country are constant
- 3) All factors of production in the country are fully and efficiently utilised. No resources are underutilised.
- 4) All factors of production are substitute but not a perfect substitute of each other
- 5) Factors of production can be shifted from the production of guns to the production of another good bread. However, shifting of resources from one good to another would reduce production of the former and increase the production of the latter as necessitated by the downward sloping PPC.

The above assumptions are an attempt to simplify a complex socio – economic aspect which is closer to reality. It is only to understand the concept. Once understood, these assumptions can be relaxed to make the situation more realistic.



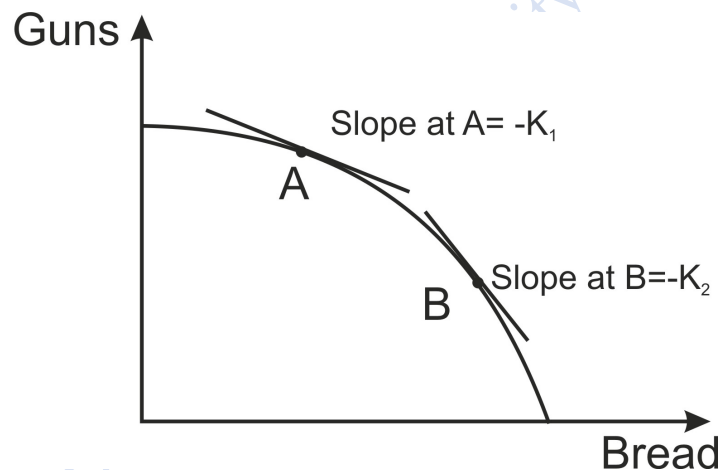
Activity 3

PPC assumes that factors of production are substitutes but not a perfect substitute of each other. Do you agree with this assumption? If not, why? Would there be any change in the shape of PPC if capital and labour are assumed to be a perfect substitute and are equally efficient?

(Hint: can the production possibility frontier be a downward sloping straight line?)

Note: Production possibility frontier lays strong foundation for trade between two countries. Questions like, why two countries must engage in trade and gains from trade can be explained using PPC.

Slope of Production possibility frontier and its interpretation

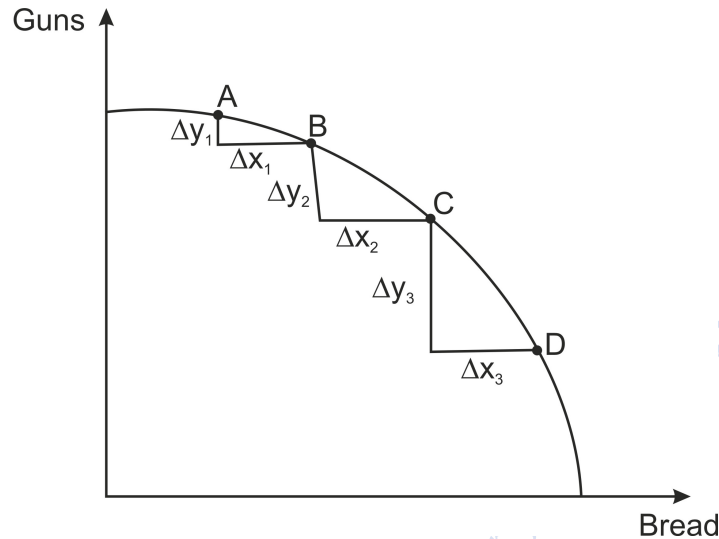


The opportunity cost of producing one good over another good can be calculated by finding out the slope of the production possibility frontier at any given point on the curve. Graphical representation is shown below:

The PPF in the graph below shows the slope at two different points A and B. Let us assume that the slope at point A is $-k_1$ (some coefficient) and at B is $-k_2$ (another coefficient), where $|k_2| > |k_1|$. Each point on PPF has different slope which represent the corresponding opportunity cost at that point. It can easily be noted that slope increases as we move from point A to point B on the PPF. The absolute value at A and B is the opportunity cost. The opportunity cost at points A and B is k_1 and k_2 , respectively. The opportunity cost of producing more bread increases as one moves from left to right. The slope at any point on



PPF, as discussed earlier, shows the marginal rate of transformation (MRT). The Marginal Rate of Transformation is given by $\Delta Y/\Delta X$.



In the adjacent figure, ΔX is constant (say 1), whereas the value of ΔY keeps changing. $\Delta Y_3 > \Delta Y_2 > \Delta Y_1$. The $MRT_{AB} = \Delta Y_1/\Delta X$

$MRT_{BC} = \Delta Y_2/\Delta X$ and $MRT_{CD} = \Delta Y_3/\Delta X$.

Since, $\Delta Y_3 > \Delta Y_2 > \Delta Y_1$ and $\Delta X = 1$,

$MRT_{AB} < MRT_{BC} < MRT_{CD}$. This explains that MRT increases as we move from top to bottom.

1.5.1 OPPORTUNITY COST

The concept of opportunity cost is similar to the marginal rate of transformation. Every decision or choice you make has an alternative option that must be foregone. Suppose you have to study two subjects – economics and mathematics – to clear an exam. Out of 24-hour day, you study only for, say, 8 hours. Now, if you devote 4 hours a day to studying economics, you have 4 hours for mathematics. Now, if you increase the number of hours to study economics to 6 hours a day, you are left with only 2 hours to study mathematics. You may score well in economics, but your marks in mathematics may suffer due to fewer hours dedicated to the subject. The value of devoting less than 2 hours to mathematics is an opportunity cost of the additional 2 hours you devoted to studying economics. Most of the time you can quantify opportunity cost and in turn monetary value can be assigned to such



costs. Now, can you correlate opportunity cost with the concept of the marginal rate of transformation?

Activity 4

A migrant worker shifts to Delhi in search of a job. He has to feed his family, educate his children, and take care of his elderly parents. He was lucky to find a job in a garment industry. He was happy to receive a salary of Rs. 15000. Few months later, he developed a bad company and started consuming liquor due to which his health deteriorated. He could not join his job for 3 months. Can you answer the following?

- What is the opportunity cost of developing a bad company for the migrant worker?
- How can he compensate for his opportunity cost of keeping bad company?
- Compare his situation with his friend who is rich and prosperous. Who will have higher opportunity cost of missing his job?

1.5.2 SUNK COST

There is another cost known as sunk cost. Sunk costs are those costs that have already been incurred but can never be recovered. One should not make their choice based on sunk costs but rather evaluate the related opportunity cost of making one decision over another. But in reality, people ignore the opportunity cost of their choice and worry more about sunk costs. Sunk costs should be ignored entirely while taking any decision. Sunk costs are excluded from the future decision-making process.

For example, suppose a firm invests one crore in setting up a research plant for new technology. It may be possible that products based on the technology find no takers in the market. Due to the absence of demand, the amount spent on the development of technology is a sunk cost since it is failed investment. Recovery of the cost incurred is not possible and should not be considered in the future decision-making process.

Sunk cost fallacy refers to an individual's behaviour of continuing with the investment already done to ensure that the investment does not turn wasteful. Such investment may lead to additional losses.

For example, you purchased a Rs. 300 ticket to see a movie in theatre. As the date approaches,

you are called for an urgent meeting on the date of movie for which ticket was purchased and conflicts with movie time. Although you should be going to your appointment, you decide to



go for the movie because you don't want the ticket go waste. This is an example of a sunk cost fallacy because you decided to attend the movie to ensure your investment was worth it. In addition, the sunk cost—in this case, the Rs. 300 you spent—wouldn't have been recovered regardless of the choice you made.

Activity 5

Now, using the concept of the production possibility frontier can you think of any situation when PPC shifts towards the right? With this thought, answer the following:

- Suppose labour and capital become two times more efficient than before. How would it impact the PPC?
- A country is experiencing continuous soil erosion and rising sea level in the coastal areas. It will have no impact on the production possibility frontier. Do you agree?
- Suppose capital becomes two times more efficient than labour. It will make the production possibility curve rotate in favour of capital-intensive commodity. Show this diagrammatically and explain with reason.
- How COVID pandemic might have impacted the production possibility frontier?

1.6 SUMMARY

Resources are those goods or services that can be utilised to produce goods and services for final consumption. Land, labour, capital and entrepreneurship are the important resources of an economy. Mismatch between demand and supply often highlight scarcity in the resources of an economy. Individuals or group who makes choices are the agent of the economy. Three central problems of an economy are what to produce, how to produce and for whom to produce. Production possibility frontier is a tool showing trade-off between the production of good X and good Y. It shows the maximum quantity of good X that can be produced for a given production level of another good, say Y, with the given level of capital and labour in the economy. Marginal Rate of Transformation is the quantity of good Y that must be given up for producing one additional unit of good X. MRT increases as one move from top to bottom.

1.7 GLOSSARY

Central Problems of an Economy: What to produce, how to produce and for whom to produce.



Economic Agents: Every individual or group who makes choices are the agent of the economy.

Marginal Rate of Transformation:the quantity of good Y that must be given up for producing one additional unit of good X

Production Possibility Frontier: a curve that shows the maximum quantity of good X that can be produced for a given production level of another good, Y, by using all resources in the economy efficiently.

Opportunity Cost: Every decision or choice you make has an alternative option that must be foregone.

Sunk Cost:costs that have already been incurred but can never be recovered.

1.8 ANSWERS TO IN – TEXT QUESTIONS

1.Labour	6. Decision makers
2. Fixed,	7.what to produce, how to produce and forwhom to produce
3. Variable	8. Optimisation of resources, attainment of equilibrium
4. Demand, supply	
5. False	

1.9 SELF – ASSESSMENT QUESTIONS

1. What is a production possibility frontier? State its various assumptions
2. What are the important features of a production possibility frontier?
3. Under what circumstances should the production possibility frontier be a downward sloping straight line? Explain.
4. What is an opportunity cost? You should be more worried about opportunity cost than a sunk cost. Why?
5. Suppose that the production of corn and robots are indicated on the X axis and Y axis, respectively. How will the PPC change if:
 - a. Factor inputs become two times more efficient than before



- b. Scientists discover a new variety of seeds that yield three times more corn

1.10 REFERENCES

- Mankiw, N.G. (2018). *Principles of Microeconomics 8th ed.*
- Frank R. H., & Cartwright, E. (2010). *Microeconomics and Behaviour*. New York: McGraw-Hill.
- Acemoglu D. Laibson D. & List J. (2017). *Microeconomics Pearson*.

1.11 SUGGESTED READINGS

- Pindyck R. S. & Rubinfeld D. L. (2018). *Microeconomics (Ninth)*. Pearson.
- Krugman P. R. & Wells R. (2021). *Microeconomics (Sixth)*. Worth. Retrieved August 30, 2022

© DDCE/COL/SOL/Univ. of Delhi



LESSON 2

GAINS FROM TRADE

STRUCTURE

- 2.1 Learning Objectives
- 2.2 Introduction
- 2.3 Using the Concept of Production Possibility Curve to Understand the Basis of Trade
- 2.4 Absolute Cost Advantage
- 2.5. Comparative Cost Advantage and Trade
- 2.6 Summary
- 2.7 Glossary
- 2.8 Answers to In-text Questions
- 2.9 Self-Assessment Questions
- 2.10 References
- 2.11 Suggested Readings

2.1 LEARNING OBJECTIVES

By the end of the chapter, students should be able to use the concept of the Production Possibility curve to understand the basis of trade. You should also be able to understand the absolute cost advantage and the comparative cost advantage

2.2 INTRODUCTION

In a traditional economy, people would work on their land and eat the fruits and vegetables grown in their fields. Later as the need increased, people would buy other goods that they could not produce in exchange for their produce. Hence, the trade began. Today, in modern society, if we look around, we find goods and services from across the world. Right from pens, clothes, TV, vehicle, fridge and so on; we are surrounded by goods which have been transported from different parts of the world. One would wonder why there is a need to purchase goods from outside the country when our own country could produce those goods? For that, we will have to understand the concept of production possibility and the gains from specialisation.



2.3 USING THE CONCEPT OF PRODUCTION POSSIBILITY CURVE TO UNDERSTAND THE BASIS OF TRADE

Let us imagine a hypothetical country named Bestland. Bestland produces two goods – Food and Clothes. Bestland does not trade with any other country and limits its consumption to only two goods that it produces. It has to allocate all its resources between the production of these two goods only. We will make use of the Production Possibility Curve to understand Bestland’s ability to produce both these goods.

A Production Possibility Curve (PPC) of the Bestland shows the production choices that can be produced in the economy. It shows the different combinations of output that the country can produce by utilising its factors of production and technology (Hutchinson, 2017). This is also known as the Production Possibility Frontier (PPF). The production capacity is further determined by the factors of production available in the country. Look at figure 1 given below:

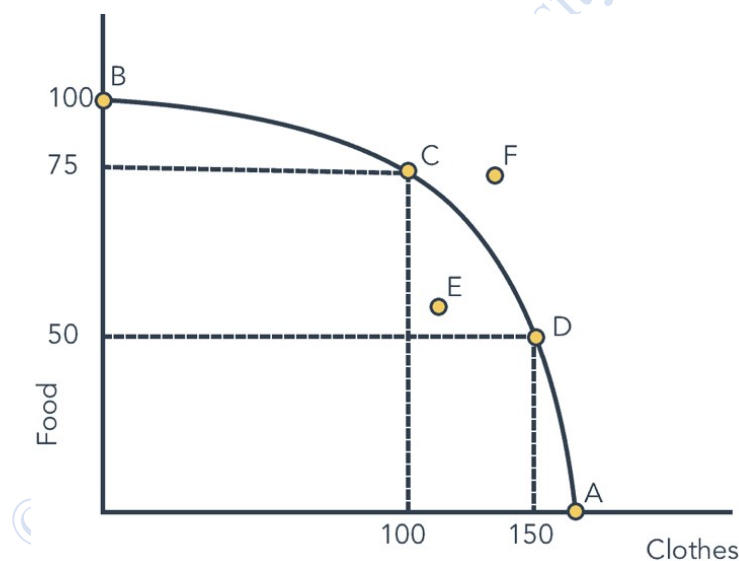


Figure 1: Production Possibility Curve

The above figure depicts Bestland’s production possibility curve. Any point on this curve represents the possible production choices which the country has, if it utilizes all its resources. Given its resources, it can produce either 75 units of food and 100 units of clothes, or it can produce 50 units of food and 150 units of clothes. So, the production takes place either at point C or at point D. If the production takes place at point E, it will be underutilising its resources as it can be better off by producing more of both food as well as



clothes. On the other hand, if the point F, which lies outside the PPC, represents the unattainable level of output.

Now let us understand what happens if we think of trading some of our goods with the neighbouring country. For that, let us start with the very simplified concept i.e., the difference in absolute cost.

IN-TEXT QUESTION

1. State True or False:

- 1) Bestland can produce 75 units of food and 150 units of clothes
- 2) Bestland can produce 160 units of clothes
- 3) Based on demand Bestland can produce the combination E and F both

2.4 ABSOLUTE COST ADVANTAGE

As we have seen the production possibility curve of Bestland. Bestland has a neighbouring country named Primeland. Prime land also produces both food as well as clothes. However, due to the advanced technology possessed by Primeland, production efficiency is much more. The production possibility curve of Primeland is given below in figure 3.

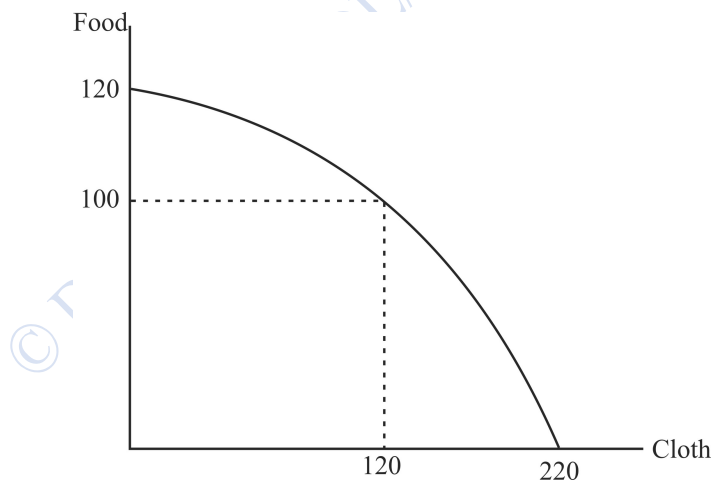


Figure 3: Production possibility curve of Bestland and Primeland

In this case, since Primeland has better resources, it can produce more of both food as well as clothes. Here, Primeland has an absolute advantage in the production of both goods. A country might have an absolute advantage in the production of certain commodities due to the



higher availability of factors of production such as labour, advanced technology or endowment of natural resources.

In this situation, where Primeland can produce more of both goods, why should it trade with Bestland? Will there be any trade at all? If we look at this only from an absolute cost perspective, we will conclude that there will be no trade. However, despite Primeland having an absolute advantage over Bestland, they both can still gain from trade. To understand this, first, you have to understand the concept of comparative advantage

IN-TEXT QUESTION

2. Mention two factors due to which a country might have an absolute cost advantage.
- a) _____
 - b) _____

2.5 COMPARATIVE COST ADVANTAGE AND TRADE

The concept of Comparative advantage is linked with the concept of opportunity cost. A country might have a comparative advantage in producing the commodity if it can produce the good at a lower opportunity cost. As you know, opportunity cost is the quantity of one good that has to be given up in order to produce an additional unit of another commodity. David Ricardo, in his book Principles of Political Economy and Taxation, gave the concept of comparative advantage.

Let us assume that without trade, the production of food and cloth by Bestland and Primeland are as follows:

Table 1: Production of Food and Cloth by Bestland and Primeland

	Bestland	Primeland
Food	75	100
Clothes	100	120

If both Bestland and Primeland continue with their production without trading, the total production of food and clothes would be 175 and 220, respectively. Now, let us understand the opportunity cost for both countries.

Look at the above table carefully to understand the opportunity cost of each country.

Bestland

- Opportunity cost of food - $75/100$, i.e., $\frac{3}{4}$
- Opportunity cost of cloth – $100/75$, i.e., $4/3$



Primeland

- Opportunity cost of food – $100/120$, i.e., $5/6$
- Opportunity cost of cloth – $120/100$, i.e., $6/5$

Now, compare the opportunity cost of food for both Bestland and Primeland. The opportunity cost of food for Bestland is $3/4$, while for Primeland, it is $5/6$. The country with lower opportunity cost enjoys a comparative advantage over the production of that commodity. Therefore, in this case, Bestland has a comparative advantage in the production of food as it has a lower opportunity cost as compared to Primeland.

Similarly, the opportunity cost of cloth for Bestland is $4/3$, while for Primeland, it is $6/5$. In this case, Primeland has a comparative advantage over the production of cloth as it has a lower opportunity cost as compared to Bestland.

Therefore, even though Primeland has an absolute advantage over the production of both food and cloth, it has a comparative advantage in the production of cloth. Therefore, Bestland should produce food while Primeland should produce cloth, and both should gain from the trade as the total output will be much higher than the one which was before trade.

Everyone has a comparative advantage in producing one good or the other. Therefore, everyone gains from trade if they specialise in producing only that commodity over which they have a comparative advantage.

Case Study

The Comparative Advantage of the US in the production of Hi-Tech Capital Goods

The United States of America has an absolute advantage over agricultural produce as well as high-tech capital goods and software. Realising its comparative advantage over the production of hi-tech capital goods, it has diverted its resources from the production of agricultural products towards specialising in high-value processor chips, complex software, and assembled products. Their share of agriculture in export has declined while hi-tech goods have increased. It has also been estimated that the US is gaining its comparative advantage in the service sector such as education, finance, and professional services. They are expected to gain from international trade by specialising in such service sector.

Source: University of Minnesota (2016)



IN-TEXT QUESTION

3. Mention three commodities on which India has a comparative cost advantage to America.
- a) _____
- b) _____
- c) _____

2.6 SUMMARY

The country is better off if it engages in trade. We studied two concepts here – Absolute cost advantage and comparative cost advantage. A country might have an absolute cost advantage over the production of commodities due to the higher availability of factors of production such as labour, advanced technology, or endowment of natural resources. Therefore, a country might engage in trade where it has an absolute cost advantage over the production of certain commodities. However, sometimes a country may not have an absolute cost advantage over the production of any of the commodities but yet may engage in trade because of different opportunity costs. When the country trades in goods which has two different opportunity cost, the country should specialise in the production of those goods where the opportunity cost is lower. Even if a country has an absolute advantage over the production of both commodities, according to comparative cost advantage, the country will specialise in producing only one commodity. This will be used to trade with other commodities.

2.7 GLOSSARY

- **Absolute Advantage** –When a country can produce the goods using fewer resources than the other country
- **Comparative Advantage** – When a country has a lower opportunity cost in the production of its goods as compared to the other country.

2.8 ANSWERS TO IN-TEXT QUESTIONS

1. a) False
- b) True
- c) False



- 2. a) Endowment of natural resources
b) Advanced Technology
- 3. a) Organic Chemical
b) Iron and Steel
c) Cotton

2.9 SELF-ASSESSMENT QUESTIONS

Q1) The table shows the production capacity of Producer A and Producer B for computer Hardware and Software.

	Computer Hardware	Software
Producer A	50	50
Producer B	30	30

Which of the following statements is TRUE?

- a) Producer A has a comparative advantage in producing Computer hardware.
 - b) Producer A has the comparative advantage in producing software.
 - c) Producer B has the absolute advantage in producing computer hardware and software.
 - d) No producer has the comparative advantage in producing either computer hardware or software.
- Q2) Rohit can either pluck 20 mangoes or 15 roses in an hour from the park. On the other hand, his friend Manpreet can pluck 50 mangoes or 25 roses in an hour from the part. Calculate the opportunity cost of both Rohit and Manpreet for both mangoes as well as roses. Who has the absolute advantage and who has the comparative advantage?
- Q3) Explain why the countries gain from trade?
- Q4) Explain how absolute cost advantage and comparative cost advantage differ from each other
- Q5) Comment on the export and import pattern of India in light of the concept of comparative cost advantage.



2.10 REFERENCES

- Mankiw, N. G. (2020). *Principles of economics*. Cengage Learning.

2.11 SUGGESTED READINGS

- Roberts, R. (2006). *Treasure Island: The Power of Trade*. Part I. The Seemingly Simple Story of Comparative Advantage. *Econlib*.
- Libby Rittenberg. (2008). *Principles of microeconomics*. Flat World Knowledge.
- University of Minnesota (2016). *Principles of Economics*. University of Minnesota Press.
- Deardorff, A. V. (2011). How robust is comparative advantage? *Comparative Advantage, Growth, And the Gains From Trade And Globalization: A Festschrift in Honor of Alan V Deardorff*, 183-195.
- Harrigan, J. (2010). Airplanes and comparative advantage. *Journal of International Economics*, 82(2), 181-194.

© DDCE/COL/SOL/University of Delhi



LESSON 3

INDIVIDUAL AND SOCIETY

STRUCTURE

- 3.1 Learning Objectives
- 3.2 Introduction
- 3.3 Individuals in the Society
 - 3.3.1 Social Consciousness and Social Relations
 - 3.3.2 Interpretation of Individuals in Different Social Domains
- 3.4 Base and Superstructure: Concept of Social Formation
 - 3.4.1 Production Relations in Capitalism
- 3.5 Summary
- 3.6 Glossary
- 3.7 Answers to In-text Questions
- 3.8 Self-Assessment Questions
- 3.9 References
- 3.10 Suggested Readings

3.1 LEARNING OBJECTIVES

The objective of this chapter is to make students aware about social consciousness and be able to understand the process of evolution of social relations. After reading the chapter, you should be able to make various interpretations of social relations. Students should also be able to understand the continuous process in the making of society's structure from an economic perspective and the role of production relations and property rights in the evolution of a society.

3.2 INTRODUCTION

Society and individuals are closely related to each other. Individuals form society based on various customs, rules and traditions. Mankind depends on society for various emotional, psychological and spiritual needs. Individuals and society are interdependent and the growth of one ensures the growth of the other. Society affects individuals in several ways as the shape and personality of an individual is hugely impacted by prevailing customs and social



conditioning. Societal force plays an important role in building society's superstructure which keeps updating and upgrading with time and space. Strong and purposeful must learn to live with the differences among each other and live as a unit. With this background, the chapter attempts to make students understand social relations and its various interpretations in the light of social, political and economic paradigm.

3.3 INDIVIDUALS IN THE SOCIETY

This chapter has as many variations as possible and layers, each holding its ground over complex relations between individuals, society, and social relations. The debate over the interdependence and relationship thereof between men and society often revolves around individuals shaping society or social conditioning determining individuals. The essence of this debate is that it has been discussed for ages and from myriad perspectives, yet the riddle remains unsolved and least understood. Social relations have varied dimensions – social, economic, political, cultural, etc. – and the amalgamation of all sizes gives society to humankind, forming an inseparable part of human existence. Social relations can be compared to three states of matter: solid, liquid, and gaseous. A solid state is a metaphor for those social values and social relations that are rigid and hard but not difficult to change. A liquid state represents those social relations that change with time in a slow but steady manner. On the other hand, a gaseous state is reflective of those social relations that adapt quickly to societal changes. A society with all three forms of social ties delegates a vital message that at any given point, the mutual co-existence of heterogeneous beliefs should not be an exception but rather the norm. The vitality of a strong and purposeful society lies in the honoring and tolerating of differences, not simply in the enjoyment of similarities.

On the flip side of it, society comprises individuals incapable of being self-sufficient in aloofness or isolation. If society is an epitome of wholeness, men are a proportion of this whole, who depend upon it to realize their peak potential of being and functioning. A man should realise his nature and potential of being a man to the fullest. Any shortfall in being a man reflects the state of the actuality that is raw and underprepared. With their initial state of rawness, human nature is in the continuous pursuit of virtues and happiness, armed by its distinctive rationality and inherent capacity.

Activity – 1

Can you recall being a child 12 years ago? You played with yourself, taking up different roles of others – the role of a teacher, a policeman, a doctor, a mother wearing a saree, etc. If you have ever done this in your distant memory, try answering the following:



- i. Were you exploring your future role in society?
- ii. Were you trying to identify yourself with either of these roles you enjoyed playing?
- iii. Did you enjoy playing only those roles which you thought were significant and powerful?
- iv. From where did you learn about these roles in your childhood?

3.3.1 Social consciousness and social relations

Consciousness is the state of being aware of and responsive to one's surroundings. It is the ability of men to perceive, interpret and understand their neighborhood. This social consciousness germinates and grows into social relations as men are constantly reminded of the fact that they affect one another. Social relations are an offshoot of family life, rules of morality set by society, and age-old customs. There are political relations that develop under the activity of state authority. The responsibilities and relationships between a government and people are defined in the mechanism of governance such as democracy, kingship, etc. Economic relations extend through the forging of social bonds around the material possession of goods and services. These relations inculcate in men a pattern of repeated behavior towards each other. Repeated behavior and inner consciousness act and react upon each other forming ideas in men. Of all social relations, relations of production and consequent economic ties are of specific importance to this chapter. In the close vicinity of economic relations, there lie relations of distributions such as the collection of rent, interest, wages, and profits.

3.3.2 Interpretation of individuals in different social domains

As per sociologists, individual (A's) power can be ascertained in terms of his interaction with his fellow beings to the extent he is able to convince others (say individual B) to comply with his desires. Every action of an individual is always shaped by his personal experience and interaction with his fellow beings in a group. Family is the starting point of that group, which expands to society at the next stage. We often hear people saying that "society" forced them to do something or not to do something. How can society force someone? Any action by an individual is not taken in a vacuum. Society throws open a set of alternatives to an individual. Existing cultural patterns and social forces leave no option for an individual but to opt for one alternative over the other. This social pressure and cultural exposure to an individual defines him and his choice.



Political theorists or Political Scientists analyse the disposition of power in society and outline the power equation between individuals, groups, and states. This balance of power comes with a responsibility upon each of them. The state is the will of the majority of people, and an individual being a smaller entity of the larger universe, has no authority to bypass the common will. It means that every individual is bound by the set of rules and regulations determined by the authority of the state.

Individuals, on the other hand, maintain that the state is for the people and not the otherwise. In other words, individuals make the state and not the state makes the individual and therefore, the state is for the convenience of the people, and any interference by the state in an individual's affair is unwarranted.

Psychologists are of the view that cognitive factors of an individual affect performance and learning. Cognitive factors refer to anything we do consciously in pursuit of learning, memory, attention, perception, and decision making. **Albert Bandura's** theory stress two important points of social learning:

- a) Occurrence of mediating process between response and stimuli
- b) Observational learning plays an important role in behavior formation

Children observe people around them and develop a perception about them behaving in various ways. They may be their parents, others within the family, TV personalities, friends in their peer group, and teachers at school. Children consider them as their role models and provide examples of behavior to observe and imitate. These behaviors may be pro-society, manly, feminine or even anti-social.

Social identity theory, as propounded by **Henri Tajfel**, is an individual's sense of who they are based on their group memberships. Group affiliation gives an individual a sense of belonging to the social world. People develop intergroup bias based on their group affiliation. They tend to positively evaluate their ingroup (ingroup favoritism) relative to the outgroup.

Economists see individuals and society through the prism of production and distribution relations. According to **Karl Marx**, the mode of production can have various structures like slave mode of production and feudal or capitalist mode of production. A society can have all the modes of production simultaneously. The mode of production and society's material means of production usually determine the social relations of production and distribution. Men develop social relations determined by repeated economic activity of production. Social relations of such a nature are weighed down by inertia and develop resistance to any change. However, *the Law of Progressive Development* says that relations based on economic



activity, for that matter, any activity under social relations, can never prevail for long. External stimuli of societal changes force men to alter their behavior. Man acts on nature and is himself acted by it in the social process of labour.

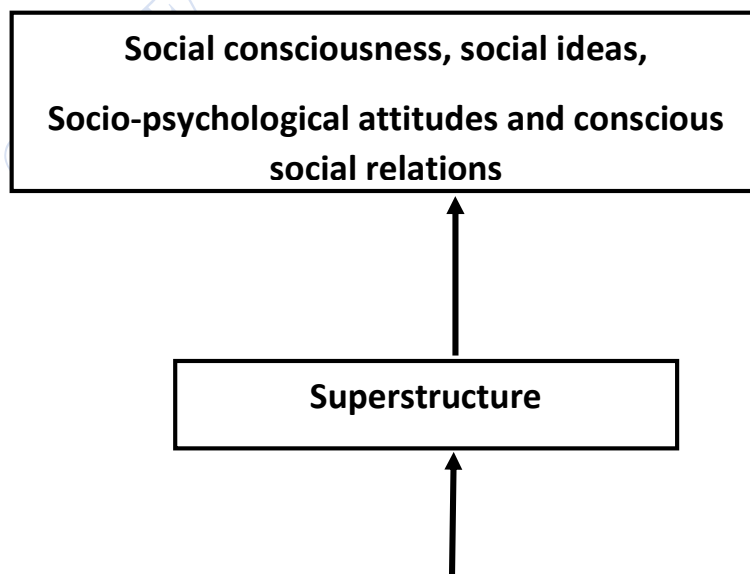
IN-TEXT QUESTIONS

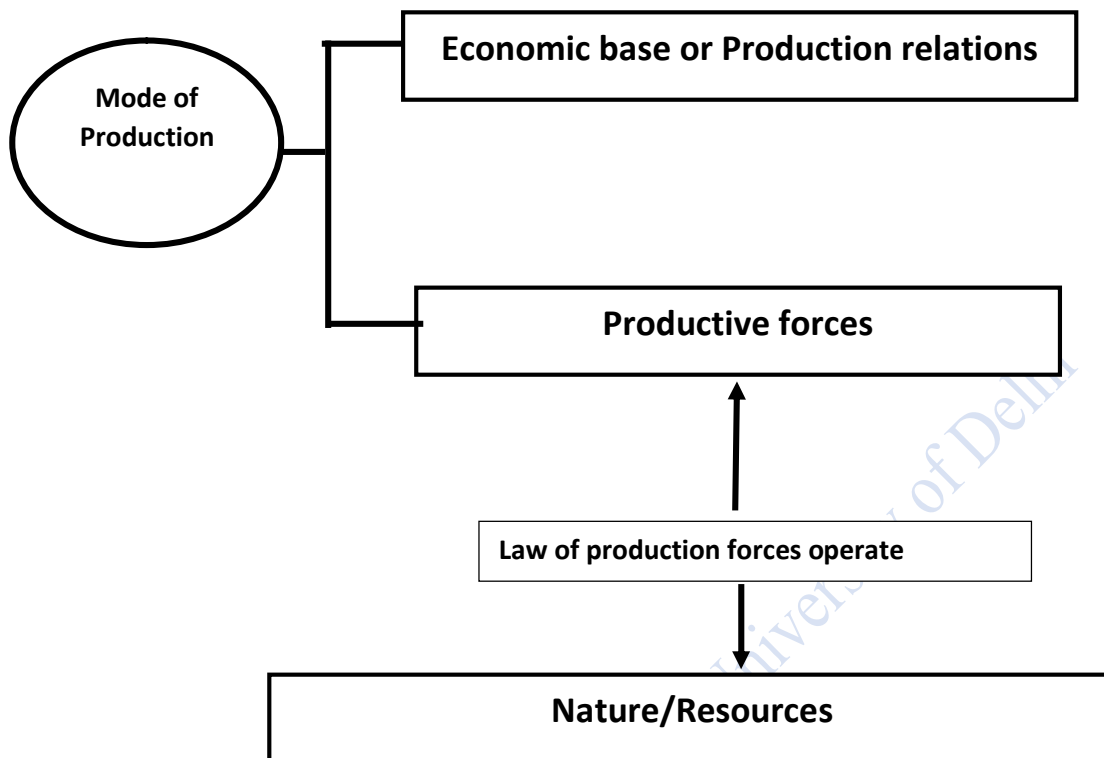
1. In what context does the author compare social relations to matter?
2. How is the relationship between men and society important?

3.4 BASE AND SUPERSTRUCTURE: CONCEPT OF SOCIAL FORMATION

In architectural science, the superstructure is the part of the building that is visible, can be touched, and felt. The base is the underground preparation, on which the superstructure rests and derives its balance and strength. However, with time, the building weakens, erodes, and the entire superstructure is demolished. A new base is made for the replacement of the previous superstructure that commensurate with people’s aspirations and fits the changing requirement of society, modernity, and need. What is true for buildings is also true for society.

Likewise, what could be society’s superstructure? A society’s superstructure consists of its culture, norms, ideology, and identities inhabited by people. These key ingredients play an important role in the formation of social institutions, political structure, and the state apparatus of governance. According to Karl Marx, these key components of the social superstructure legitimize the base. Let us understand the overall concept with this figure below:





The diagram above has social consciousness at the topmost part with nature and natural resources at the bottom. In between these two, the entire process of progressive social development takes place. The law of progressive development of productive forces operates on natural resources. These forces operate for human survival as people work on these natural resources to feed themselves. In the process, nature acts upon people. Such action and reaction between nature and people is a continuous process. The combination of labor and means of labor results in the development of productive forces.

3.4.1 Production relations in capitalism

The type of “property” plays an important role in determining social relations. “Property,” being a legal concept, plays an important role in defining different kinds of social relations. Owners of truly private property are free to do anything with their assets and do not have to abide by any social or political obligations. Thus, the owners of private assets are separated from people and society. A step further is capitalist property relations. A capitalist society is one in which property is not only privately held, but the sole purpose of a capitalist society is also capital accumulation. Of late, there is a new concept of generalized private property in



which rights to and obligations related to “natural” resources, commodities produced out of labor, etc. are distributed in a manner that stability of interdependence of social categories continue to remain in balance. People belonging to different social categories (not individuals) who possess these generalized properties are not free to dispose of them as per their personal choices. This is majorly because people belonging to one category (as owners of one resource) carry social obligations to people belonging to another category (owners of another resource). This chain endures relationships with different social categories despite social inequality.

However, individuals entering different forms of social production relations are indispensable and independent of their will– generally called “relations of productions”. It should be noted that property relation is the driving force behind relations of productions. Private property and generalized private property have different implications for production relations, that men enter is independent of their choice.

IN-TEXT QUESTIONS

3.What forms of a society’s superstructure?

4.What forms an integral part of a society?

3.5 SUMMARY

Individuals with similar beliefs and virtues form a society with similar values. Change in these parameters may give birth to a separate society with different values and virtues. Individuals form an important component of the society. Society is to serve individuals. Social relations are comparable to three states of matter. Consciousness is the state of being aware of and responsive to one’s surroundings. It is the ability of men to perceive, interpret and understand their neighbourhood. Sociologists, Political scientists, Psychologists and Economists have homogeneous but slightly differentiated interpretations of individual and the society. A society’s superstructure consists of its culture, norms, ideology, and identities inhabited by people. These key ingredients play an important role in the formation of social institutions, political structure, and the state apparatus of governance.

3.6 GLOSSARY

Social Consciousness: The state of being aware of and responsive to one’s surroundings

Social Learning: Every Observational learning and mediating process between response and stimuli



Society's Superstructure: Social structure that includes the culture, ideology, norms, and identities that people inhabit. It also includes social institutions, political structure, and the state—or society's governing apparatus. Superstructure grows out of the base and represents interests of the ruling class.

3.7 ANSWERS TO IN-TEXT QUESTIONS

- | |
|--|
| <ol style="list-style-type: none">1. In the context of social rigidities2. Section 3.3.23. culture, norms, ideology, and identities inhabited by people4. Production and distribution relations |
|--|

3.8 SELF-ASSESSMENT QUESTIONS

1. Draw the distinction between a sociologist and political theorists' approach toward defining the relationship between individuals and society
2. Do you think Economists' approach to establishing linkage between individuals and society is more appealing than thinkers from other domains? Elaborate
3. What is mode of production, and how it is the determining factor behind social relations?
4. The covid pandemic has brought many changes around you. Can you mention a few examples of changes in social relations due to the pandemic? Did you experience any change in relations among your classmates during the pandemic? Could you list other such changes around you?
5. Discuss the foundation of the society's superstructure. A mismatch between base and superstructure lays the foundation of a new superstructure. How?
6. Action and reaction between nature and human beings are a continuous process. Elaborate the statement in the context of society's superstructure.
7. How property relation is the driving force behind the evolution of production relations?
8. Men cannot realize their true potential in isolation. Do you agree with the statement? However, as per the research paper by Norman Li and Satoshi Kanazawa published in



the British Journal of Psychology, intelligent people prefer to be alone. Can you explain this contradiction?

3.9 REFERENCES

- Storper, M. (2005). Society, Community, and Economic Development. *Studies in Comparative International Development*, 39(4), 30–57.
- Cockshott, P., & Cottrell, A. (2002). The relation between economic and political instances in the communist mode of production. *Science & Society*, 66(1), 50-64.
- Betai, R. S. (1961). INDIVIDUAL AND SOCIETY. *Annals of the Bhandarkar Oriental Research Institute*, 42(1/4), 141–149.
- Nugent, D. (1993). Property Relations, Production Relations, and Inequality: Anthropology, Political Economy, and the Blackfeet. *American Ethnologist*, 20(2), 336–362.
- Coser, L. A. (1957). Social Conflict and the Theory of Social Change. *The British Journal of Sociology*, 8(3), 197–207.

3.10 SUGGESTED READINGS

- Marx, K., Mandel, E., & Fernbach, D. (1992). *Capital: A critique of political economy*. Penguin Books in association with New Left Review
- Harris, A. L. (1948). The Social Philosophy of Karl Marx. *Ethics*, 58(3), 1–42.



LESSON 4

DEMAND AND SUPPLY

STRUCTURE

- 4.1 Learning Objectives
- 4.2 Introduction
- 4.3 The Market
- 4.4 Understanding Demand
 - 4.4.1 Determinants of Demand
 - 4.4.2 Individual and Market Demand Curve
 - 4.4.3 Movement and Shift in the Demand Curve
- 4.5 Understanding Supply
 - 4.5.1 Determinants of Supply
 - 4.5.2 Individual and Market Supply
 - 4.5.3 Shift and Movement in the Supply Curve
- 4.6 Summary
- 4.7 Glossary
- 4.8 Answers to In-text Questions
- 4.9 Self-Assessment Questions
- 4.10 References
- 4.11 Suggested Readings

4.1 LEARNING OBJECTIVES

By the end of the chapter, student should be able to understand the laws of demand and supply and the factors affecting the laws of demand and supply. Further, you will be able to understand the difference between movement in the demand curve and the shift along the demand curve. You will also understand the difference between the supply curve and shift along the supply curve.



4.2 INTRODUCTION

As you must have read in the previous unit that the demand is unlimited, and the resources are limited. Therefore, all these resources need to be allocated an efficient manner. But then you must be wondering how to allocate the resources efficiently.

Allocation of resources depends on the price of the goods, which are determined by the demand and supply of the goods. Therefore, the buyers and the sellers of the goods in the market, determine their price. In this chapter, you will be reading about what is demand and supply and how it functions in the market.

But before we proceed further, let's understand what a market is and how the buyers and sellers interact in such markets

4.3 THE MARKET

A market is a place where different buyers and sellers meet. A market can be a physical market like the local mandis, or it can be an international market. A market can be non-physical as well such as e-market. It can be product-specific markets like a leather market or a general market that deals with different products. There can be markets based on the degree of competition – perfectly competitive market, monopoly, monopolistic etc. which you will be studying in the later units. Here, we will be taking into consideration only the competitive market. In layman's terms, a competitive market is one where the goods sold are exactly the same, and all the buyers and all the sellers collectively determine the price of the good. No single buyer or seller can influence the price. It is important to understand how a perfectly competitive market function. There are some examples of competitive markets such as vegetables, fruits, eggs, milk, metals, petrol etc.

Now, suppose you go to purchase potatoes from the market. Have you ever thought about how their price is determined? The price of one kilogram of potatoes is not randomly fixed by the vegetable vendor. Rather it is based on the economic phenomenon of demand as well as supply of potatoes. How good was the production of the potatoes, and what was the cost of labour involved in potato farming? How much is the transportation cost of bringing the potatoes from the agricultural field to the market from which you are buying? But wait, are these factors enough to determine the price? Imagine a scenario where most people in the village do not prefer buying potatoes for some reason. Do you think that will have some impact on the price of potatoes? Let's find out. But before that, let's understand demand and supply in detail



IN-TEXT QUESTIONS

1. We, as a consumer, purchase our goods from different marketplaces. Can you think of any two types of markets?
- a) _____
- b) _____

4.4 UNDERSTANDING DEMAND

To understand demand, first, we need to have a clear distinction between desire and demand. Desire is just the wish to have a certain commodity. The concept of desire is not associated with purchasing power or the willingness to pay. But when we talk about demand, demand is the desire to have a particular commodity backed by purchasing power as well as the willingness to pay for the same. For example, as a student, you may desire to possess a laptop. But that is simply a desire because you may not have the purchasing power to buy the laptop. However, if your parents are willing to purchase the same for you, they are the ones creating the demand for the product, here laptop. Hence, what differentiates a desire from demand is the purchasing power and the willingness to pay. Now, since you have understood the difference between desire and demand, it is also important for you to understand the difference between demand and quantity demanded.

Demand is the willingness of the buyer to buy a commodity at a given price whereas **quantity demanded** is the actual quantity which the consumer is willing to buy at the given price. Again, taking the example of potatoes. If Raghu says that he is willing to buy potatoes at Rs 15 per kg, it represents demand because, at the given price, Raghu has shown his willingness to purchase potatoes. Now, when Raghu says that he is willing to purchase three Kilogram of potatoes at Rs 15 per kg, he is talking about the exact quantity that he is willing to purchase at the given price. This, therefore, represents the quantity demanded by Raghu.

IN-TEXT QUESTIONS

2. State True or False
- a) Wants are limited and resources are unlimited _____
- b) Quantity demanded of a commodity is the exact quantity that a person is willing to purchase at a given price _____
- c) A market is a place where different sellers and buyers meet _____



- d) Demand and quantity demanded holds same meaning in economics _____
- e) Desire is associated with the wish to possess a commodity, irrespective of the purchasing power _____

4.4.1 Determinants of Demand

As a buyer, you must have observed that your demand for a certain commodity is influenced by many factors. Let us study some of these factors in detail.

- 1) **Price:** One of the most prominent reasons influencing demand for the commodity is the price of the good. Suppose you get Rs 100 every month as pocket money. In the summer season, you purchased one ice cream every day with this pocket money which costs you Rs 2 per day i.e., Rs 60 per month. One fine day, the price of ice cream rose to Rs 5. Will you still be able to afford to buy one ice cream every day with your pocket money of Rs 100? Surely not. Because for that you will be needing Rs 150 ($\text{Rs } 5 * 30 = \text{Rs } 150$) as your pocket money. So, then what do you do? You will have to decrease your consumption of ice cream. You might consider buying ice cream on alternate days which will cost you Rs 75 now ($\text{Rs } 5 * 15 = \text{Rs } 75$), which still falls within your budget of Rs 100. Therefore, when the price of the commodity increases, the quantity demanded decreases and vice versa. This is also known as the **law of demand**.

Look at the table below where the price and quantity demanded of ice cream (per month) has been listed:

Table 1: Price and Quantity demanded of Ice cream (per month)

Price (In Rs)	Quantity Demanded
20	20
30	15
40	10
50	7
60	5



Carefully observe this table. Here, as the price of ice cream increases, you will demand less and less of it because your monthly pocket money is fixed. Now, let us plot this in a graph

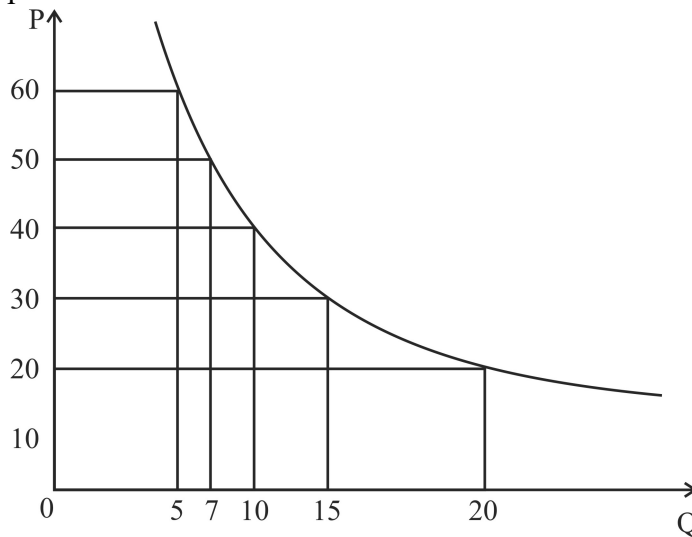


Figure 1: Demand Curve

As you can see in figure 1, when we plot each of these price and quantity demanded, we get a negatively sloped curve. This is also the demand curve of the good under consideration and depicts how much quantity of the good will the person demand at a given price

Now imagine the same being associated with the choice among thousands of people across the world buying different commodities such as vegetables, fruits, milk, and so on. As the price of the commodity increases, people generally decrease their consumption of it because their income is fixed. Hence price becomes an important determinant of the demand for a product.

- 2) **Income:** In the previous example, now imagine that your parents have increased your pocket money. Instead of getting Rs 100, now you get Rs 200 as your pocket money. How will that affect your demand for ice cream? Won't you feel like having ice cream twice a day? Or you might consider buying expensive ice cream or you might even spend some money on purchasing chocolates, which you were not purchasing earlier. In any of the cases above, you are creating an additional demand – either for ice cream or chocolates. Thus, with the increase in income, the quantity demanded will increase and with the decrease in income, the quantity demanded will decrease. How can we represent the same in the demand curve?

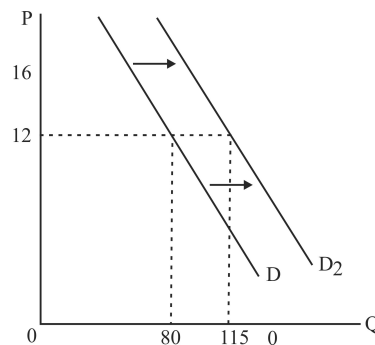


Figure 2: Rightward shift in demand curve due to change in Income

As you can see in figure 2, with the increase in income, the demand curve shifts parallel to the right. Now, at the price of Rs 12, an individual buys 80 units of a commodity. Now at the same price, s/he buys 115 units. Therefore, with the increase in income, the quantity demanded has increased.

- 3) **Taste and Preference:** In many cases, the demand for a commodity is increased or decreased due to the change in taste and preference of an individual. This change can be due to change in fashion, technological upgradation, change in preference for goods due to age factors, change in season and so on. Imagine yourself when you were a kid. Your demand for pencils, water bottles, and lunch boxes, was very different from your demand for the same today. Similarly, we all remember having a landline phone at home. But now because of technological improvements, we no longer prefer buying a landline phone. Rather, a smartphone is much more in demand these days. Therefore, all these factors lead to a shift in the demand curve. Let's understand the same with the help of a graph.

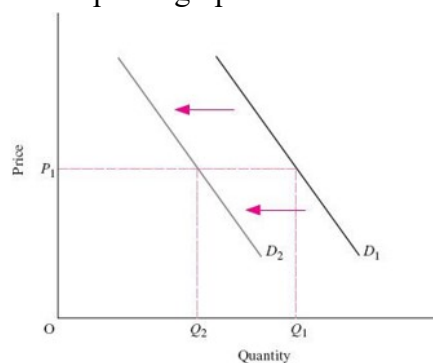


Figure 3: Leftward shift in demand curve due to change in technology against a commodity say landline phones



Let's say the figure 3 above represents the demand for landline phone. With the upgradation of technology, people have increased their demand of mobile phones and decreased their demand for landline phones. Therefore, the demand curve has shifted to the left. So even when the price of landline phones is the same i.e., P_1 the quantity demanded has reduced from Q_1 to Q_2

- 4) **Price of Related Goods:** If you observe things around you, you will realize that many commodities are used in combination. For example - car and petrol, sharpener and pencil, mobile phone and SIM cards and so on. These kinds of goods which are generally used in combination are known as complementary goods. Can you think about how demand changes in the case of complementary goods? Suppose X_1 and X_2 are two complementary goods. When the demand for X_1 increases, the demand for X_2 increases as well, and vice versa.

Just like complementary goods, we have another set of goods where we generally use either of the two – pen and pencil, shoes and sandals, tea and coffee and so on. These kinds of goods where generally one is substituted for the other are known as substitute goods. How will the demand curve function in the case of a substitute good? Suppose S_1 and S_2 are two substitute goods. If the price of S_1 increases, people will shift to buy more S_2 . For example, tea and coffee are substitute goods costing Rs 10 each. One fine day, the cost of tea rose to Rs 15, and the cost of coffee is the same, i.e., Rs 10. The demand for coffee will increase and people will shift to buying more coffee than tea.

There are many other factors due to which the demand changes. You should now be able to understand how those factors will affect the demand.

IN-TEXT QUESTIONS

3. What will happen to the demand for the good in the following circumstances:
- Increase in the price of complementary goods _____
 - Decrease in the income _____
 - Increase in wealth of the family _____
 - Increase in the price of substitute goods _____
 - Decrease in the price of the goods _____



4.4.2 Individual and Market Demand Curve

Whatever we have studied till now explains how the individual's demand changes as per changes in different factors. As a student of economics, you should also be able to understand the demands of all the individuals in society, i.e., the market demand.

Let us go back to the example where Raghu was willing to purchase 3 kilograms of potatoes at Rs 15 per kg. Now, another consumer Ahmed is willing to purchase 8 kgs of potatoes at Rs 15 per kg. Together both Raghu and Ahmed are willing to purchase 11kg ($8 + 3 = 11$) of potatoes at Rs 15. This becomes the market demand for the good. Therefore, at the same price, the sum of the quantity demanded by all the individuals represents the market demand.

Let's also understand this with the help of a graph.

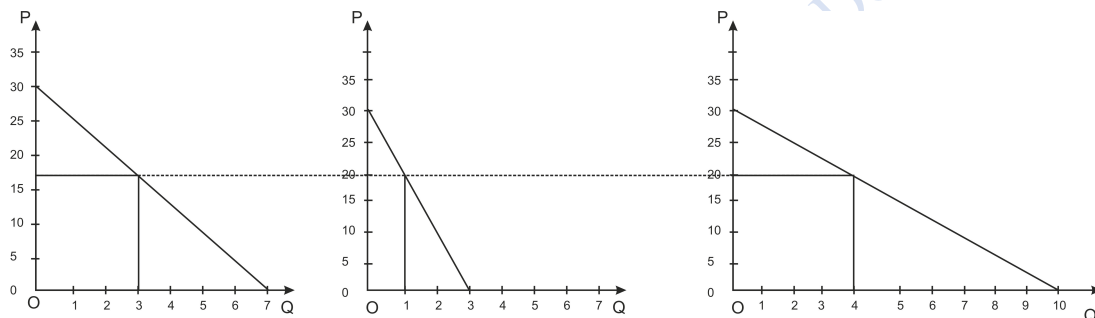


Figure 4: Individual and Market Demand Curve

As you can see in the Figure 4 above, market demand is the sum total of individual demand, or we may also say that the market demand curve is the horizontal summation of the individual demand curve. At the price of Rs 20, the quantity demanded by first individual is 3 units and by second individual is 1 unit. Now for market demand, we can see that at the same price, i.e., Rs 20, the quantity demanded is 4 units (3 units + 1 unit)

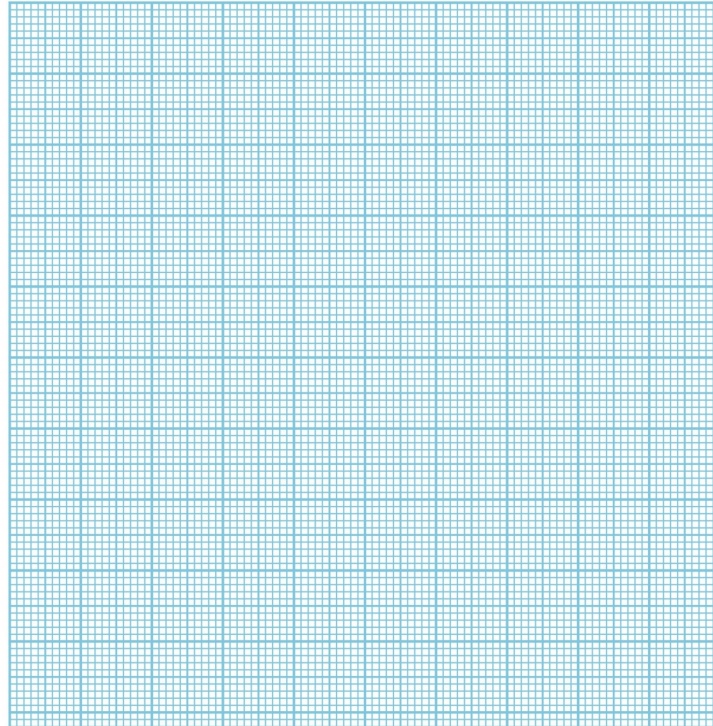
IN-TEXT QUESTIONS

4. Suppose there is a market for bread consisting of only two buyers – Rishi and Sana. Given below is the individual demand schedule of Rishi and Sana.

Price	Rishi	Sana	Market Demand
10	22	18	
18	18	12	
20	12	10	
25	6	8	



Calculate the market demand and plot the market demand curve.



4.4.3 Shift and Movement in Demand Curve

In economics, the shift of the demand curve and the movement along the demand curve - are two different concepts. It is important to have clarity about the difference between the two.

Movement along the demand curve

A movement along the demand curve takes place when there is a change in quantity demanded due to the **change in price**. Here, price is the only factor which leads to the movement along the demand curve, and hence the quantity demanded changes. There can be two kinds of changes here:

- **Upward movement:** Upward movement takes place when the price of a commodity increases leading to a decline in the quantity demanded. Since the quantity demanded has declined, it is also known as the contraction of demand. In the graph below, the demand curve has not shifted rather there is an upward movement within the same demand curve

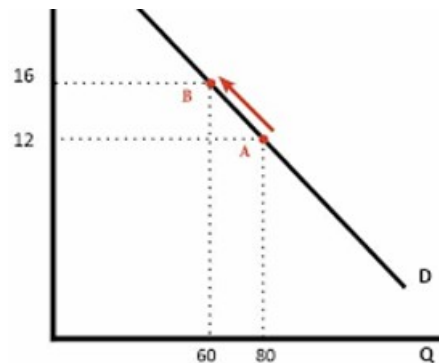


Figure 5: Upward movement in Demand Curve

- **Downward movement:** Downward movement takes place when the price of the commodity decreases leading to an increase in the quantity demanded. Since the quantity demanded has increased, it is known as the expansion of demand. In the graph below, as you can see, within the same demand curve, there is downward movement.

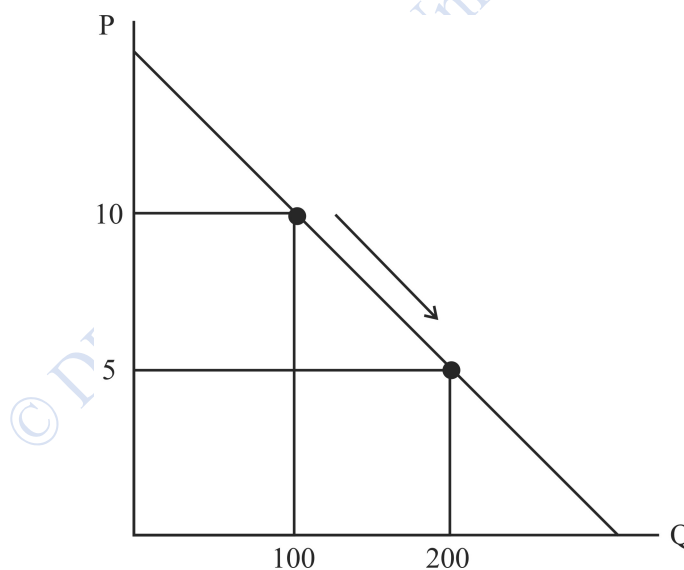


Figure 6: Downward Movement in Demand Curve

Shift in the demand curve

A shift in the demand curve is where the entire demand curve moves either to the right or to the left, i.e., it displays a change in demand at each possible change in price. A shift in the



demand curve takes place because of changes in factors other than price. As we have learnt in the previous section that different factors can lead to changes in the demand curve. A change in all these factors, other than the change in price, leads to a shift in the demand curve. The shift in the demand curve can be of two types:

- **Rightward Shift:** Suppose the income level of your family increases due to which you can consume more ice cream now. This increase is not due to a change in price, but rather due to the increase in income (i.e., non-price factor). Hence the demand curve will shift to the right. This is also known as increase in demand.

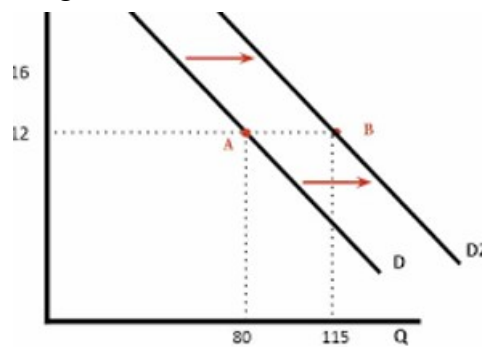


Figure 7: Rightward Shift in Demand Curve

- **Leftward Shift:** Now imagine that it's the month of December and it is very cold outside. You no longer feel like eating ice cream. Hence, your demand for ice cream will also decline. Again, this decline in demand for ice cream is not due to a change in price but rather a change in weather, changing your preference (i.e., non-price factor). In such a case the demand curve will shift to the left. This is also known as a decrease in demand.

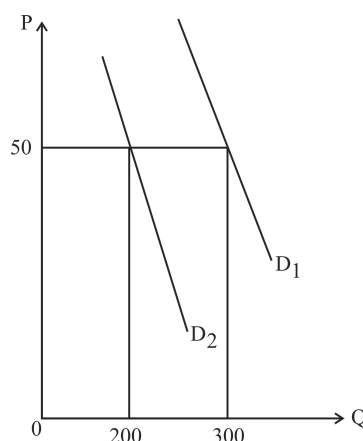


Figure 8: Leftward Shift in Demand Curve



IN-TEXT QUESTIONS

5. Specify in each of these cases whether there will be a shift or a movement in the demand curve
- Increase in the price of goods _____
 - Change in Seasonal demand of goods _____
 - Increase in wealth of the family _____
 - During wartime, the demand for weapons _____
 - Increase in train ticket sale due to vacation _____

4.5 UNDERSTANDING SUPPLY

Since you have understood demand now, let us just shift our point of view to understand the market from the seller's perspective. A seller in the market is motivated by his own personal interest. They might be willing to either increase sales, increase profit margin or increase their revenue. So, to understand supply, you should keep the objective of a seller in your mind.

The quantity of a commodity that a producer is willing to sell at various prices in a given time is referred to as **supply**. Similar to demand, the concept of supply has various distinguishing characteristics. Just like demand, there is a slight difference between the supply and quantity supplied. Supply is a measure of the number of goods that the market can provide at various prices. **Quantity supplied**, on the other hand, shows the number of goods that the producer will provide at a given price.

Now, let us understand what the different determinants of supply are.

4.5.1 Determinants of Supply

- Price of the commodity:** Suppose a shopkeeper sells a pen for Rs 10 and at this price he is able to make a small profit of, say, Re 1. He was selling 100 quantities of pens. Now suddenly the price of the same pen increases to Rs 15. The seller will be able to sell more, say 200, because the marginal cost (MC) of producing 200 is higher than the MC at producing 100. Therefore, the seller will increase the supply of the pens from 100 to 200. This phenomenon where, other things being the same, when the



price of commodity increases, the quantity supplied increases. This is also known as the **law of supply**. This supply line is also known as MC line.

Now, look at the following demand schedule concerning the price of the commodity and the quantity supplied:

Price	Quantity supplied
10	100
15	150
20	200
25	250

Let us plot the graph to understand how the supply curve looks like.

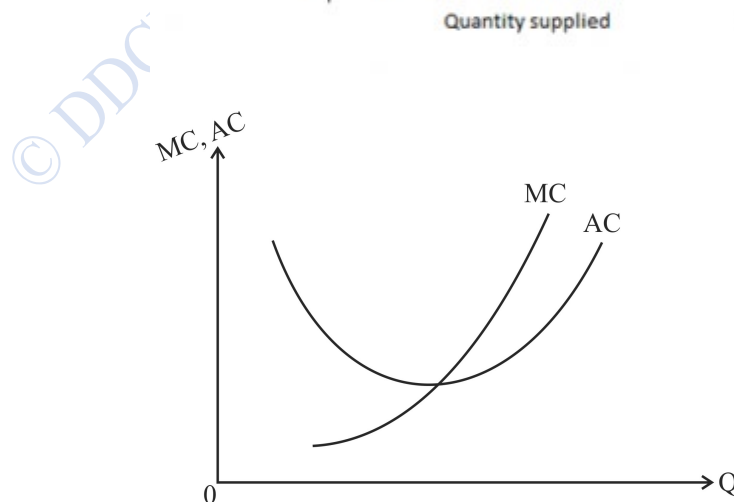
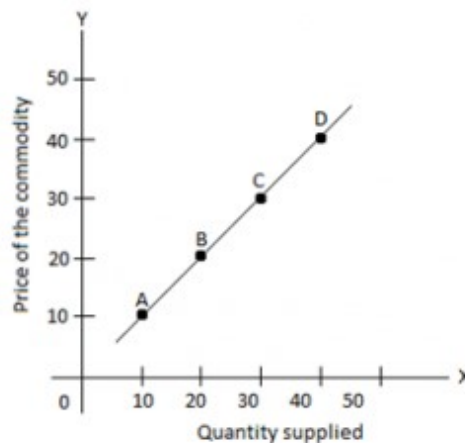


Figure 9: Supply Curve



As you can see in figure 9, the supply curve is positively sloping, i.e., it is moving upward from left to right. This positive slope shows that there is a positive correlation between price and quantity supplied, i.e., as the price increases, the quantity supplied increases and as the price decreases, the quantity supplied decreases.

- **Cost of Production:** Cost of production have a direct impact on the seller’s potential profits. A rise in the cost of production or the input price of the firm deters them from manufacturing and hence decreases the supply of the good. Suppose a firm X produced bread. The price of wheat, which is used as raw material in the bread, has increased. This will increase the cost of the production of bread. Since the price of bread is still the same in the market, the profit of firm X declines. Hence, the supply curve will shift towards the left, as shown in the figure 10 below.

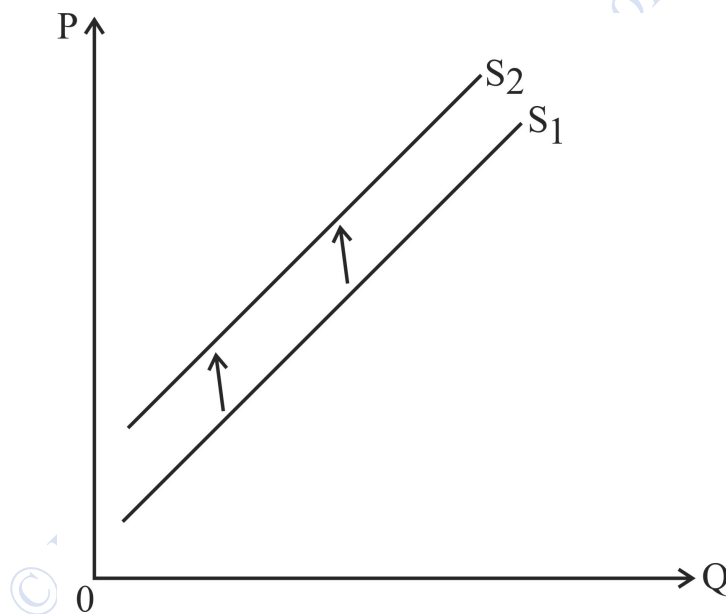


Figure 10: Leftward shift in Supply Curve due to Increase in the cost of Production

- **Technological Upgradation:** With the improvement in technology, the production process becomes efficient, and more goods can be produced in less time. Hence the supply of such goods increased. The supply curve in such a case will shift to the right, as shown in the graph below.

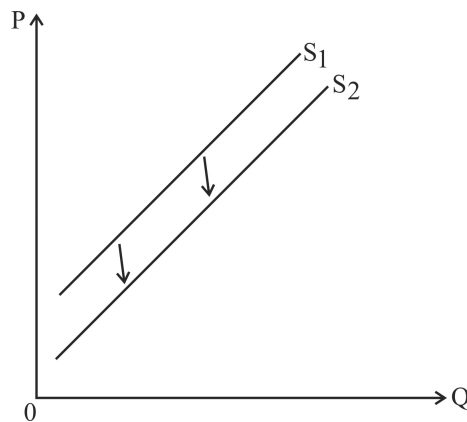


Figure 11: Rightward shift in Supply Curve due to Technological Upgradation

- **Number of sellers:** With more sellers participating in the market, the overall supply of goods in the market would increase. For example, the market for smartphones. A few years back, there were just a handful of producers of smartphones in the market. Now with the increase in the number of sellers, the supply of smartphones in the market has increased manifold.

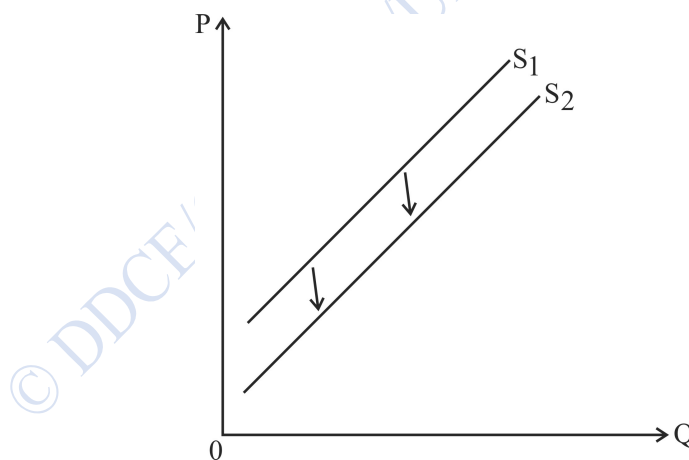


Figure 12: Rightward shift in Supply Curve due to Increase in the number of Sellers

IN-TEXT QUESTIONS

6. Apart from these, there can be many other factors which may lead to an increase/decrease in the supply of goods. Can you think of any other two factors?
- 1) _____



2)

4.5.2 Individual and Market Supply

As we have read about the market demand curve, similarly the market supply curve is the sum of all the individual suppliers in the economy. Let us say, we are concerned about the market for comic books. We have just two shops in the area – Shop 1 and Shop 2. In figure 13 given below, at the price of \$20, the supply by firm 1 and firm 2 is 3 units and 4 units, respectively. These are their individual supply curve. When we do the horizontal summation of the individual supply curve, we get the market supply curve. Remember, here the price is the same, only the quantity supplied is added to get the market supply curve. So, the market supplies 7 units at the price of \$20.

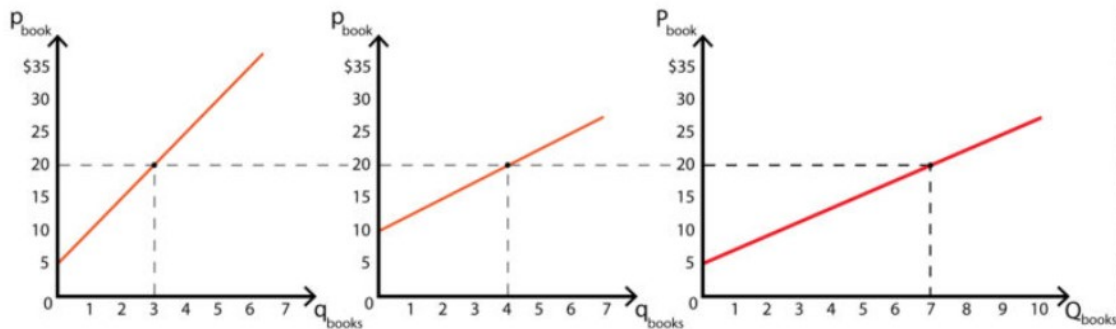


Figure 13: Individual and Market Supply Curve

4.5.3 Shift and Movement in the Supply Curve

Similar to the shift and movement in the demand curve, there are shifts and movements in the supply curve.

Movement along the supply curve

A movement along the supply curve takes place when there is a change in quantity supplied due to the **change in price**. Here, price is the only factor which leads to the movement along the supply curve, and hence the quantity supplied changes. There can be two kinds of changes here:

- **Upward movement:** Upward movement takes place when the price of a commodity increases leading to an increase in the quantity supplied. Since the quantity supplied has increased, it is also known as the expansion of supply



- **Downward movement:** Downward movement takes place when the price of the commodity decreases leading to a decrease in the quantity supplied. Since the quantity supplied has decreased, it is known as the contraction of supply.

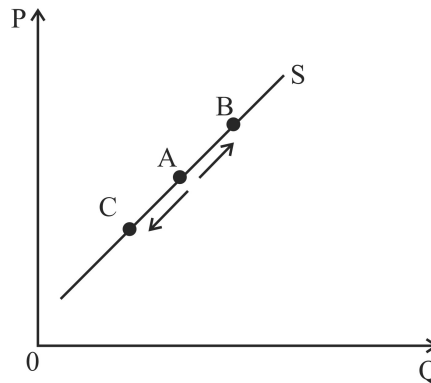


Figure 14: Upward and Downward Movement in Supply Curve

In the figure 14 above, there is no shift in the supply curve. Rather, on the same supply curve, there is upward and downward movement leading to increase or decrease in the quantity supplied.

Shift in the supply curve

A shift in the supply curve is where the entire supply curve moves either to the right or to the left, i.e., it displays a change in supply at each possible change in price. A shift in the supply curve takes place because of factors other than the price of the good. As we have learnt in the previous section that different factors can lead to changes in the supply curve. A change in all these factors, other than the change in price, leads to a shift in the demand curve. The shift in the supply curve can be of two types:

- **Rightward Shift:** Suppose the supply of raw material, say, milk has increased in the market. Because of this, there has been a decline in the price of milk, reducing the cost of producing cheese. You as a seller of cheese will increase the production and supply more cheese to the market. This leads to a rightward shift in the supply curve. The increase in supply has not been due to the change in the cost of the cheese itself, rather it is because of the change in the input price. Hence there is an **increase in supply**.
- **Leftward Shift:** Consider a situation where the war broke out between two countries A and B. Country A was the major producer of coffee and used to supply coffee throughout the world. However, because of the war, coffee production in country A stopped and most of the resources were diverted towards supplying arms and



ammunition to the army. In such a case, country A was unable to supply the same amount of coffee around the world as it used to do earlier. Therefore, the supply curve of coffee shifts to the left. This is also known as **decrease in supply**.

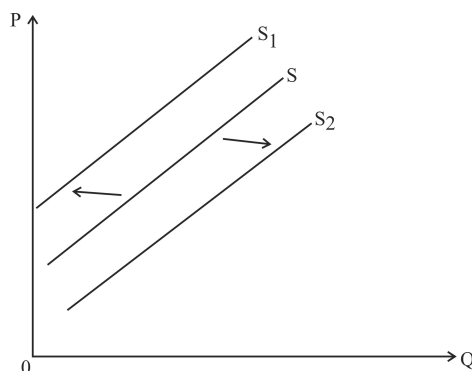


Figure 15: Rightward and Leftward Shift in Supply Curve

Figure 15 above depicts the shift in the supply curve. There is a rightward shift when the supply curve S moves to S₂, and there is a leftward shift when the supply curve moves from S to S₁.

4.6 SUMMARY

The intersection of demand and supply determines the price of the product. There are different factors affecting the demand, such as the price of the goods, change in income of the consumer, change in preferences etc. From individual demand curves, we can derive the market demand curve by horizontal summation. When the demand curve changes due to a change in price, it is known as movement along the demand curve and the change in quantity demanded is termed as expansion or contraction in demand. Similarly, when the demand changes due to factors other than price, it is known as a shift in the demand curve and the subsequent change in quantity demanded is termed as an increase or decrease in demand. There are different factors affecting supply curve such as cost of production, number of sellers etc. From individual supply curves, we can derive the market supply curve by horizontal summation. When the supply curve changes due to a change in price, it is known as movement along the supply curve and the change in quantity supplied is termed as expansion or contraction in supply. Similarly, when the supply changes due to factors other than price, it is known as a shift in the supply curve and the subsequent change in quantity supplied is termed as an increase or decrease in supply.

4.7 GLOSSARY

Demand – The willingness of the buyer to purchase the commodity at a given price



Quantity Demanded – The willingness of the buyer to purchase a fixed quantity of the commodity at a given price

Law of Demand – With the increase in the price of a commodity the quantity demanded decreases and with the decrease in the price of a commodity the quantity demanded increases

Market Demand – The horizontal summation of the individual demand

Supply –The willingness of the seller to sell the commodity at a given price

Quantity Supplied –The willingness of the seller to sell a fixed quantity of the commodity at a given price

Law of Supply – With the increase in the price of a commodity the quantity supplied increases and with the decrease in the price of a commodity the quantity supplied decreases

Market Supply –The sum total of individual supply

4.8 ANSWER TO THE IN-TEXT QUESTIONS

1. Online Market and Anaaj Mandi	4. 40, 30, 22, 14
2. a) False	5. a) Movement
b) True	b) Shift
c) True	c) Shift
d) False	d) Shift
e) True	e) Shift
3. a) Decreases	6. Resource Licensing and Improvement in Transportation
b) Decreases	
c) Increases	
d) Increases	
e) Increases	

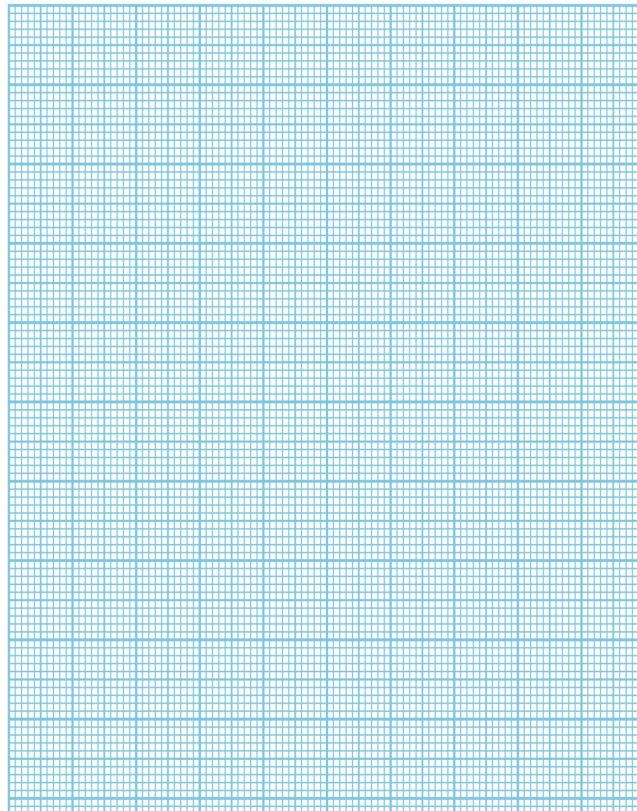
4.9 SELF-ASSESSMENT QUESTIONS

1. What do you understand by demand and how is it different from the quantity demanded?



2. Given below the are supply schedules of two sellers A and B. Can you calculate the market supply schedule and plot the same, showing the individual supply curve of A and B and the subsequent market supply curve

Price	Individual A	Individual B	Market Supply
10	25	20	
13	23	15	
16	19	11	
21	15	9	
25	11	8	
33	7	3	





- Q3) Two goods – Tea and biscuit are complementary. Suppose the price of tea increases, can you explain the impact of this increased price on the demand for tea, demand for biscuits, quantity supplied of tea and quantity supplied of biscuits?
- Q4) Why does the supply curve slope upward? Explain.
- Q5) Suppose one part of the country was not well connected with the transportation system. With the building of road and railway infrastructure, connectivity has improved, thereby enabling easy passage of goods and commodities. The raw material used in the production of commodity P was located in one such location which is not connected with rail and road transportation. Can you comment on how this improved connectivity will impact the supply of commodity P?

4.10 REFERENCES

- Mankiw, N. G. (2020). *Principles of economics*. Cengage Learning.
- Pindyck, R. S., & Rubinfeld, D. L. (2014). *Microeconomics*. Pearson Education.

4.11 SUGGESTED READING

- Mankiw, N. G. (2020). *Principles of economics*. Cengage Learning.
- Pindyck, R. S., & Rubinfeld, D. L. (2014). *Microeconomics*. Pearson Education.
- Acemoglu, D., Laibson, D., & List, J. (2021). *Microeconomics, Global Edition eBook*. Pearson Higher Ed.
- Salvatore, D. (2008). *Microeconomics: theory and applications*. OUP Catalogue



LESSON 5

ELASTICITY OF DEMAND AND SUPPLY

STRUCTURE

- 5.1 Learning Objectives
- 5.2 Introduction
- 5.3 Price elasticity of Demand and its Determinants
 - 5.3.1 Computing Price Elasticity of Demand: Numerical
 - 5.3.2 Elasticity of Demand for a Linear Demand Curve
 - 5.3.3 Calculating Price Elasticity: Total Revenue Method
- 5.4 Some other Concepts of Elasticity
- 5.5 Elasticity of Supply and its Determinants
 - 5.5.1 Computing Price Elasticity of Supply: Numerical
 - 5.5.2 Price Elasticity of Supply: Graphical
- 5.6 Summary
- 5.7 Glossary
- 5.8 Self-Assessment Questions
- 5.9 Answers to the in-text Question
- 5.10 References
- 5.11 Suggested Readings

5.1 LEARNING OBJECTIVES

By the end of the chapter, students should be able to understand the concept of elasticity of demand and supply. You should also be able to calculate elasticity and also draw them graphically

5.2 INTRODUCTION

What comes to your mind when we say that something is elastic? The stretch or flexibility. How good the stretch is, makes it more elastic than others. Something similar lies in the concept of demand or supply elasticity as well. Elasticity in economics is understood as the responsiveness of the buyers and/or the sellers towards a change in the market situation.



When it is related to demand it is known as elasticity of demand and when the same is related with supply it is known as elasticity of supply. You will read about them in detail in this chapter.

5.3 ELASTICITY OF DEMAND AND ITS DETERMINANTS

As you read in the previous chapter that as the price of ice cream increases, the demand for the same decreases. But this is a very generic understanding. If I want to know an even more precise information– By how much will the demand decrease if the price of Ice cream increases from Rs 10 to Rs 15? This depends on the elasticity of demand, i.e., the responsiveness of the buyers towards the change in such price. It may happen that despite an increase in price, there will be no change in the pattern of demand. What if I still continue to consume the same quantity of ice cream as I used to when the price was Rs 10. We call this a perfectly inelastic demand. There can be other extreme situation as well where with the price of ice cream being increased to Rs 15, my quantity demanded for ice cream falls down to zero. This is a case of perfectly elastic demand.

In other words, when there is no change in the quantity demanded with the increase in price, it is known as perfectly inelastic demand and when there is a large change or fluctuation in the pattern of quantity demanded with the slightest change in price, it is known as elastic demand. Elasticity of demand basically reflects how willing are the consumer to change their demand due to change in price. There can be various reasons for to have such willingness or non-willingness. The main reasons of elasticity of demand, also known as determinants of demand, are as follows:

- **Nature of goods:** A good can fall in the category of either necessary or luxury goods. Necessary goods are those goods where you cannot make any compromise in terms of quantity consumed. Such kind of goods are considered necessary in their daily lives. Some of such goods are – milk, oil, drinking water, pen, salt, etc. Since these are considered important in daily lives, even if price increases the consumption almost remains the same. Hence necessary goods are demand inelastic. On the other hand, there are some goods, whose consumption can be decreased or increases, if there is a change in price because such goods are not considered as absolute necessity. Examples of such goods are comic books, biscuits, cars, AC, fridge, etc. Since people can postpone the consumption of such goods with the increase in price, these goods are demand elastic.



- **Availability of substitutes:** There are many goods where the substitutes are easily available. For example, suppose the price of Colgate toothpaste increases, people may shift to buy other similar products such as Pepsodent, DantKanti etc. In such cases the elasticity of demand is high because of the availability of the substitutes. Similarly, there can be other products for which there are no close substitute. For example, suppose the price of LPG cylinder increase, there is no close substitute to it. People may not turn to using wood or cow dung cakes to light fire and cook food. Hence, we can say that the LPG cylinder has inelastic demand.
- **Multiple use of good:** The elasticity of good also changes by the kind of usage that the good has. If the good has multiple uses, and there is an increase in price, the usage is reduced to only the most important one. For example, if the price of electricity rises, the consumption is reduced to more necessary uses such as lighting bulb and fans. However, when the good has limited use, it becomes difficult to change in pattern of consumption. For example, petrol is mostly used for vehicles. Hence, with the increase in price, the consumption cannot be reduced much.
- **Percentage share of the budget:** How much percentage of your budget are you spending on a particular goods, also defines the elasticity of the good. Consider the example of a match box. The price of matchbox might increase from Re 1 to Rs 2 i.e., there might be a doubling of the price. Since, Rs 2 forms a very small part of your budget, you may not be concerned even if the price increases. Hence the demand for such goods is relatively inelastic. On the other hand, suppose you need to buy a packet of chips which costs Rs 40 earlier but now the price has increased to Rs 70. Your demand for the same will decline. Hence in such cases the demand for the packet of chips is elastic.
- **Time factor:** Time plays important role in several economic decisions. In economics, we broadly understand time as – short run and long run. Suppose there is an increase in the calling rate which is charged by telecom service provider – Airtel. In the short run, you may not necessarily be able to suddenly shift to some other service provider. However, in long run, you might shift to Jio. Hence in the short run, the elasticity of demand is relatively inelastic while in the long run, the demand is elastic. Another way to look time as a determinant of elasticity of demand is whether consumption can be postponed. If the consumption can be postponed then the demand is elastic and if it cannot be postponed, then the demand is inelastic.



IN-TEXT QUESTION

1. Given below are some of the goods. Write whether the demand for such goods will be Elastic or Inelastic and your reason for the same.
 - a) Salt _____
 - b) Milk _____
 - c) Cars _____
 - d) LPG cylinder _____
 - e) Samsung Smart phone _____

5.3.1 Computing Price Elasticity of Demand: Numerical

Now since you understand the concept of elasticity, you should be in the position to calculate the same. We use a simple formula for the same.

$$\begin{aligned}
 \text{Price Elasticity of Demand} &= \frac{\text{Percentage Change in Quantity Demanded}}{\text{Percentage Change in Price}} \\
 &= \frac{\text{Change in Quantity Demanded}}{\text{Change in Price}} * \frac{\text{Price}}{\text{Quantity}} \\
 &= \frac{\Delta Q}{\Delta P} * \frac{P}{Q}
 \end{aligned}$$

Let us solve this with the help of an example.

Ritika loves to purchase video games from the pocket money she gets from her father. After a few months, the price of video games increased leading to a decrease in the quantity demanded by her. The demand and supply schedule for Ritika is given below:

Price (In Rs)	Quantity
100	8
170	5

Now let us calculate the price elasticity of demand.

Change in Quantity = (Final Quantity – Initial Quantity)



$$= (5-8) = -3$$

Change in Price = (Final Price – Initial Price) = (170 – 100) = 70

$$\text{Elasticity} = \frac{-3}{70} * \frac{100}{8} = -0.54$$

What do we understand by this value of -0.54? Here the negative sign connotes the negative relationship between the price and quantity demanded. Hence the value of price elasticity of demand always ranges from 0 to minus infinity, i.e., it does not have a positive value for a normal good. For the analytical purpose, we ignore the negative sign. A higher value of price elasticity of demand denotes greater responsiveness of demand to the change in price and vice versa.

Mid - Point method for calculating the price elasticity

In the above question, if you calculate the price elasticity of demand by using the same numbers but reversing the order of price and quantity, we have a different answer. The new demand schedule will be:

Price (In Rs)	Quantity
170	5
100	8

Using the same formula, the price elasticity of the good will be:

$$\text{Elasticity} = \frac{3}{-70} * \frac{170}{5} = -1.46$$

Here, as you can see that even when we are talking about the same product, the value of price elasticity of demand changes as we change the order of it. In that case, we need to adopt another method for calculation i.e., the mid-point method or average method. The formula for the same is:

$$\text{Price Elasticity of Demand} = \frac{\text{Change in Quantity Demanded}}{\text{Change in Price}} * \frac{\text{Average Price}}{\text{Average Quantity}}$$

In this formula, rather than using initial price and initial quantity, we will be using average price and average quantity, i.e., the mid-value of price and quantity. Now, lets calculate using the same set of data.



$$\begin{aligned} \text{Price Elasticity of Demand} &= \frac{\Delta x}{\Delta p} * \frac{p}{x} \\ &= \frac{-3}{70} * \frac{135}{6.5} \\ &= -0.90 \end{aligned}$$

IN-TEXT QUESTION

2. State whether True or False
- a) Price elasticity of demand for a normal good can be positive or negative _____
 - b) The value of price elasticity of demand ranges from negative infinity to positive infinity _____
 - c) An elasticity of zero means that the demand for good is perfectly inelastic _____

5.3.2 Elasticity of Demand for a Linear Demand Curve

On a linear demand curve, the elasticity of demand varies at different points. As you know the demand curve which we witness most of the time is downward sloping demand curve. In a linear demand curve, the slope of the curve at each point is the same, however, it has different elasticity at different point. Why is it so? This is because a slope represents the ratio of change of two variables i.e., Price and demand whereas the elasticity represents the ratio of percentage change in two variables.

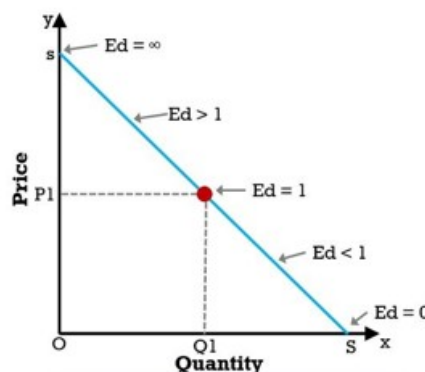


Figure 6: Elasticity at different points on a straight-line demand curve

Therefore, as you can see in the above diagram, the price elasticity of demand is zero where it touches the horizontal axis or x-axis, and it is infinity where it touches the vertical axis or y-



axis. The mid-point of the demand curve has the elasticity of one. Any point above this has the elasticity greater than one and any point below this has the elasticity less than one. The price elasticity of demand will fall as we move down and to the right along the curve

IN-TEXT QUESTION

3. Fill in the blanks

- a) The value for elasticity of demand for an inelastic demand curve will be _____
- b) The value of price elasticity of demand ranges from _____ to _____
- c) When the percentage change in demand is more than the percentage change in price, it is known as _____ demand
- d) An inelastic demand curve has _____ slope compared to an elastic demand curve

5.3.3 Calculating Price Elasticity: Total Revenue Method

By now you already know how to calculate elasticity with the given value of price and quantity. You also know how to find out the elasticity using the demand curve. Here we will study one more method of calculating elasticity i.e., the revenue method. As you must be knowing that total revenue is the product of price and quantity

$$\text{Total Revenue} = \text{Price} * \text{Quantity}$$

With the help of total revenue, we can also find the elasticity of demand. If the demand is elastic, the percentage change in quantity demanded will be more than the percentage change in price so much so that the total revenue declines. Therefore, if the demand is elastic, with increase in price, the total revenue decreases and vice versa. When the price falls, total revenue increases.

On the other hand, if the demand is inelastic, the percentage change in price is more than the quantity demanded. The total revenue in such case increases. Hence, if the demand is inelastic, with increase in price, total revenue increases and vice versa. When price of a good falls, total revenue decreases.

In case of unitary elastic, the percentage change in price exactly offsets the percentage change in demand. Hence the total revenue remains the same. This is the case of unit elastic.



Elasticity of demand	Changes	Total Revenue
Elastic	% Change in Price < % change in Quantity demanded	Increases when price decreases and decreases when price increases
Unitary	% Change in Price = % change in Quantity demanded	Remains same
Inelastic	% Change in Price > % change in Quantity demanded	Decreases when price decreases and increases when price increases.

Case Study

Consider a situation where to attend the class of Microeconomics for the course BA (H) Economics, you commute every day using the metro. Metro is the best available option for you as compared to other options such as bus, cab service and own vehicle in terms of expenses, traffic, time taken, parking space and so on. The metro pass for students' costs Rs 500 per month. Now suppose, the price of the metro pass from next month onwards increases to Rs 610. We all are cost sensitive, so we might be prompted to switch to the other modes of transportation. However, comparing other factors such as public buses whose timings are uncertain plus the road traffic will add to delay, cab services which are too expensive for students and own vehicle where one might consider the petrol cost along with road traffic and parking hassles. Considering all the above factors, you still think that commuting by metro is the best choice, despite the increase in price. So here, we see the case of inelastic demand. Now let's add some numbers to it.

The price of metro pass increases from Rs 500 to Rs 610. With initial price, the metro officials sold 1500 passes and after the increase the price, the number of passes sold is 1350.

Now, the percentage change in Price = $\frac{(610 - 500)}{(610 + 500)/2} * 100 = 19.81\%$

Percentage change in Quantity = $\frac{(1350 - 1500)}{(1500 + 1350)/2} * 100 = -10.52\%$

By calculating the percentage change in quantity and price, we can see that the percentage change in price is greater than the percentage change in Quantity demanded. Therefore, we are convinced that this is the case of an inelastic demand. But how much is the exact value of elasticity?



$$\text{Elasticity of Demand (E}_d\text{)} = \frac{\text{Percentage Change in Quantity Demanded}}{\text{Percentage Change in Price}}$$

$$E_d = \frac{-10.52}{19.81} = -0.53$$

Now we can also see the value of price elasticity of demand which is - 0.53. If the value of price elasticity of demand is less than 1, we say that it is an inelastic demand. Now, let's calculate the revenue generated in both the cases.

$$\text{Total Revenue in first case (TR}_1\text{)} = 500 * 1500 = \text{Rs } 750000$$

$$\text{TR}_2 = 610 * 1350 = \text{Rs } 823500$$

Here, with the increase in price, an additional revenue of Rs 73500 is generated. So we can say that with the increase in price, the revenue generated increases, it is the case of inelastic demand.

IN-TEXT QUESTION

4. Now suppose, your institution arranges a college bus which will provide the pick and drop facilities at nominal price, say Rs 200, per month. What do you think will happen to the demand for metro pass? Will the demand for metro pass increase or decrease? What can we say about the elasticity of demand in such case?

5.4 SOME OTHER CONCEPTS OF ELASTICITY

Apart from the concept of price elasticity of demand, we have some other concepts of elasticity of demand, which are used in economic analysis frequently. We will discuss about Income Elasticity of demand and cross price elasticity of demand

Income Elasticity of Demand: The change in demand may not necessarily be due to change in price. Suppose you start working as an intern and earn Rs 3000 per month. With this money earned, you will be willing to spend it to buy goods of your requirements. So, then you are creating a demand for those products which you are purchasing. Here, the demand for the product has been generate not because of the price of the product but because of the income. Therefore, the income elasticity of demand measures the change in quantity demanded due to change in income.

$$\text{Income Elasticity of Demand} = \frac{\text{Percentage Change in Quantity Demanded}}{\text{Percentage Change in Income}} = \frac{\Delta x}{\Delta I} * \frac{I}{x}$$



As mentioned above, with the increase in income, the quantity demanded of the same would increase. However, this is the case only for the normal goods. There are some other goods, the demand for which will decrease with the increase in income. Say for example, with increase in income you might not be willing to travel in a non-airconditioned coach of Indian railways. However, with the increase in income your preference of airconditioned coaches increases. Therefore, in this case, the non-airconditioned coach of Indian railways is an inferior goods. For inferior goods, the income elasticity is negative while for normal goods, the income elasticity is positive.

Cross Price Elasticity of Demand: As you have already read that the elasticity of demand of demand is influenced by various factors. One such factor is the price of related goods. These related goods can be either a substitute or a complementary goods. Now, the cross-price elasticity of demand measures the change in the demand for the goods due to the change in the price of related goods.

$$\begin{aligned}\text{Cross Price Elasticity of Demand} &= \frac{\text{Percentage Change in Quantity Demanded}}{\text{Percentage Change in Price of other good}} \\ &= \frac{\Delta Q_x * P_y}{\Delta P_y * Q_x}\end{aligned}$$

In case of substitute goods such as milkshake and smoothies, if the price of milkshake increases, the cross-price elasticity of demand for smoothies increases. This means that the demand for smoothies increases, not because of its own price but because of the change in price of the substitute goods. The elasticity here measures such change in demand for smoothies, due to increase in price of milkshake

In case of complementary goods such as printer and cartridge, if the price of printer increases, the demand for cartridge will also decline as people will reduce their demand for printer. The cross elasticity of demand here would measure how much the demand for cartridge has declined due to increase in the price of printer.

5.5 ELASTICITY OF SUPPLY AND ITS DETERMINANTS

Having understood the price elasticity of demand, we will try to understand the price elasticity of supply. To understand the price elasticity of supply, you have to think from a supplier's point of view by imagining yourself to be the producer of some goods. This will help you to quickly grasp the concept.

As you have already read the law of supply which says that as the price increases, the quantity supplied also increases. Now, we want to measure how much will the increase in



quantity supplied be, due to the change in the price. This can be done using the formula of price elasticity of supply. What exactly is price elasticity of supply? Price elasticity of supply is the responsiveness of quantity supplied to the change in price i.e., it measures the percentage change in quantity supplied divided by percentage change in price. If there is a substantial change in the quantity supplied due to a small change in price, the supply curve is known to be elastic. If there is only a slight change in the quantity supplied due to change in price, it is known as inelastic supply.

There are several factors that determine the elasticity of supply. Some of them are as follows:

Time Factor: One of the most important factors affecting the elasticity of supply is the time. To increase or decrease the production, there are lots of inputs required in terms of labour, raw material, capital, land etc. Therefore, a producer requires some time to arrange for these factors of production, in order to change in quantity supplied in the market. When there is sufficient time in hand to adjust the supply, then the supply is elastic. When there is not enough time to adjust the supply, the supply becomes inelastic. Precisely that is the reason why we say that the supply is inelastic in the short run while it is elastic in the long run.

Storage Facility: If there is enough storage or warehouse facility, it becomes easier for the producer to store their production and reduce the supply, when the price of the good falls. However, imagine a scenario when enough storage facilities are not available. In such cases, even if the price of goods decreases, the producers have to still maintain the same supply as they have no place to stock up their produce. Such a situation often emerges in the case of perishable goods such as fruits, vegetables, flowers, milk, etc. Therefore, when adequate storage facility is available, the quantity supplied would be elastic whereas if enough storage facility is not available, the quantity supplied will be inelastic.

Barrier to entry: Suppose as a producer of electrical equipment. You see that the price of smart phones is rising rapidly, and you would like to venture into the smart phone market. However, it might not be very easy to start the production as and when needed. There are several licensing requirements which are needed to enter the industry. Along with that there are technological barriers as well. There might be some advanced technology needed which you, as a producer, might find it difficult to procure those technologies. All these constitute barriers for you to enter the industry. Therefore, if there are no barriers to entry the quantity supplied would be elastic as suppliers would find it easier to enter or exit the industry as per the market conditions, thereby altering the supply of the good. However, in case where there are barriers to entry, the quantity supplied would be inelastic.



Mobility of factors of production: As you already know, to produce a good we need several inputs i.e., land, labour, capital, raw materials etc. Imagine you are the producer of cake and confectionary items. Your resources are diverted more towards confectionary item than towards cake. Now due to certain reasons, the competing bakery store is shut down and there is an increased demand for cake because of upcoming Christmas and New Year celebration. So, the price of cake has increased, and you want to quickly move your resources towards production of cakes. In many cases, the factors of production are immobile i.e., it is not easier to divert the factors from production of one goods towards others due to several reasons such as earmarking of budget, expertise and experience, technology and so on. In such cases where the factors are immobile, the quantity supplied is inelastic whereas in cases where it is easier to substitute the production of one good towards other, the supply is considered to be elastic.

IN-TEXT QUESTION

5. Can you list three determinants of supply elasticity
- a) _____
- b) _____

5.5.1 Computing Price Elasticity of Supply: Numerical

With this, we will now calculate the price elasticity of supply. As you already know that the price elasticity measures the responsiveness of quantity supplied to the change in price, the formula for the same is:

$$\begin{aligned}\text{Price Elasticity of Supply} &= \frac{\text{Percentage Change in Quantity Supplied}}{\text{Percentage Change in Price}} \\ &= \frac{\text{Change in Quantity Supplied}}{\text{Change in Price}} * \frac{\text{Price}}{\text{Quantity}} \\ &= \frac{\Delta Q_s}{\Delta P} * \frac{P}{Q_s}\end{aligned}$$

Let's solve this with the help of an example:

Khushbu is the owner of fast-food chain and her most selling product is pineapple cheese pizza. With the increase in the price of pizza, she wants to increase her supply so as to increase her revenue. Her supply schedule is as follows:



Price	Quantity Supplied
Rs 180	220
Rs 200	250

Using the mid-point method explained above, lets solve this.

$$\text{Price Elasticity of supply (E}_s\text{)} = \frac{\text{Change in Quantity Supplied}}{\text{Change in Price}} * \frac{\text{Price}}{\text{Quantity}} = \frac{0.064}{0.053} = 1.21$$

Hence the price elasticity of supply for pineapple cheese pizza is 1.21.

5.5.2 Price Elasticity of Supply: Graphical

As we have already read in case of demand curve, the slope of supply curve also helps us to understand the elasticity of the same. The steeper the slope, the lesser will be the elasticity. Similarly, the flatter the slope, the more will the elasticity. Through graphical method, we will be studying the five common cases of elasticity

- Perfectly Inelastic Supply
- Inelastic Supply
- Unitary Elastic Supply
- Elastic Supply
- Perfectly Elastic Supply

Let us understand them one by one.

- **Perfectly Inelastic Supply**

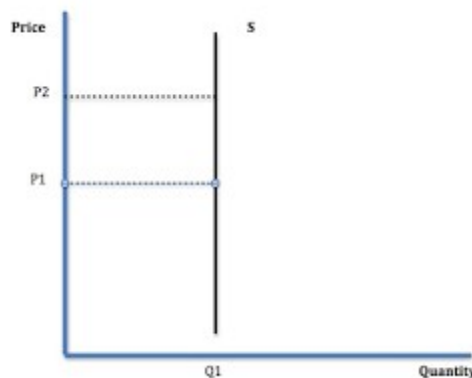


Figure 7: Perfectly Inelastic Supply



In case of perfectly inelastic supply, the supply curve is a vertical line parallel to y-axis. This implies that even when the price of the good increases, the supply remains constant. As shown in the figure, the price of the good has increased from P1 to P2. However, the quantity remains constant at Q1. This may happen in the scenario where the supply is seen in short run because in short run the capital is fixed. It also takes time to procure land and machinery in order to increase the production. Also, in situation where the supply has reached its maximum capacity, it might not be possible to increase the supply even if the price increases. For example, the increased urbanisation has increased the price of land. Despite an increase in price of land, the supply of land is constant and after all the land has been utilized, the supply becomes inelastic. In such cases the elasticity of supply is zero

- **Inelastic Supply**

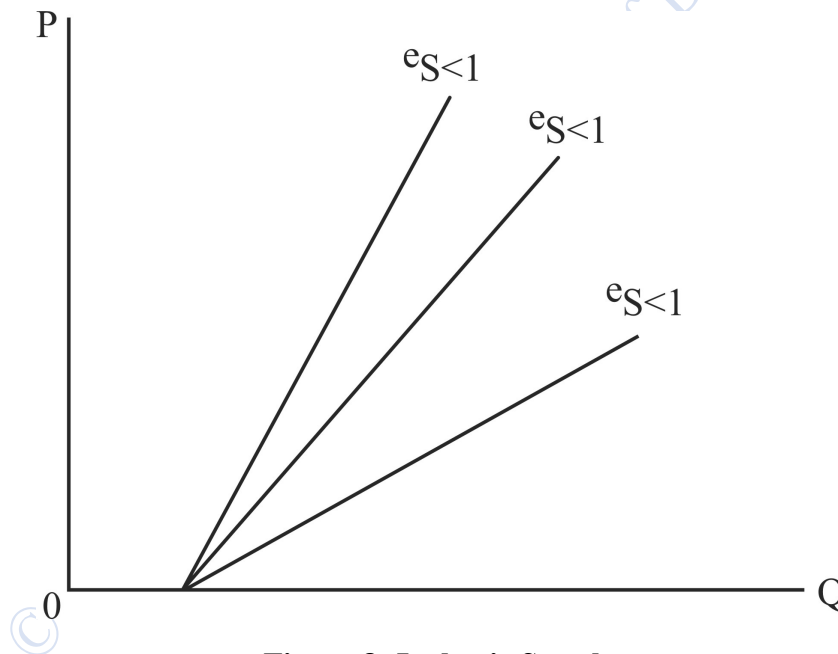


Figure 8: Inelastic Supply

In case of an inelastic supply, the supply curve is steeper and the change in price is less than that of change in quantity. One of the examples of inelastic supply can be seen in case of real estate. Even if the price of real estate increases in a particular locality, there might not be a sudden increase in the supply of constructed houses. It takes time to build a house with all its amenities. Therefore, such market is considered as inelastic. In such cases the elasticity of supply is less than 1



- **Unitary Elastic Supply**

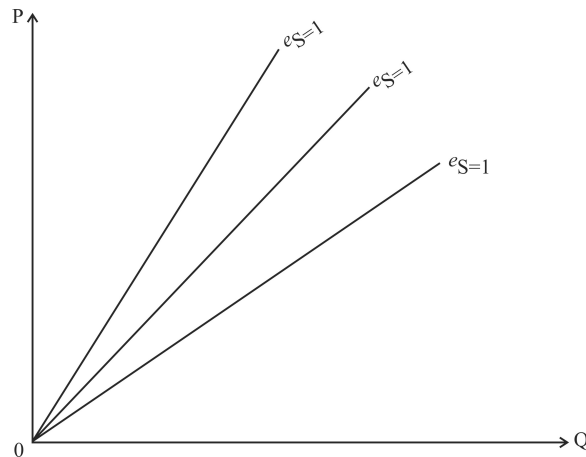


Figure 9: Unitary Elastic Supply

In case of unitary price elasticity, the percentage change in price is exactly equal to the percentage change in quantity. We can take the example of decorative light or earthen pots. During the festive season, when the demand for decorative lights or earthen pots increases, increasing the price of the same, the supply also increases accordingly. If the percentage change in supply is equal to the percentage change in price, then the elasticity is equal to one.

- **Elastic Supply**

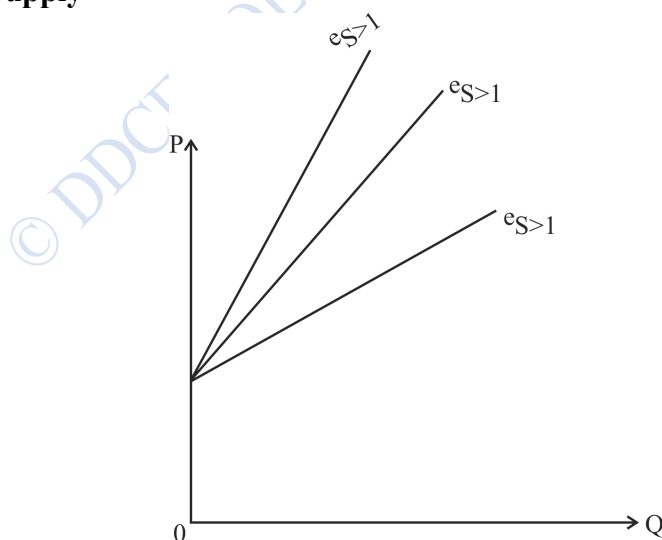


Figure 10: Elastic Supply



The supply curve is said to be elastic when the percentage change in the quantity supplied is more than the percentage change in price. We can take the example of increase in the price of sanitizers. The production of sanitizer does not take much time, nor does it require an advanced technological knowhow. With the COVID pandemic, there was an increase in the price of sanitizers. This caused the supply of sanitizers in the market to increase manifold. The elasticity of supply in such cases are more than one

- **Perfectly Elastic Supply**

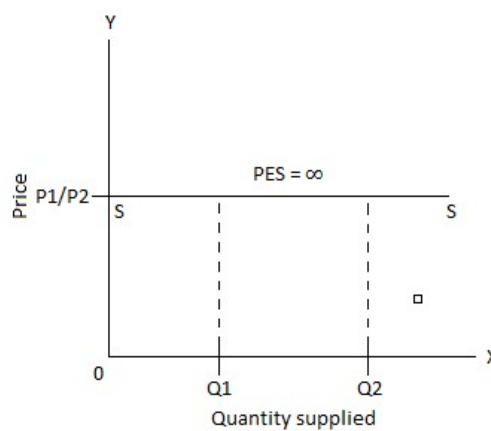


Figure 11: Perfectly Elastic Supply

Perfectly elastic supply is when the supply with the slightest change in the price, there is a large change in quantity supplied. Here, in the graph, the initial price and quantity supplied of the goods are P_1 and Q_1 respectively. Any amount of good can be supplied at the given price. In real life, it is difficult to find an example which fits in the description of a perfectly elastic supply. One of the close examples would be the perfectly competitive labour market. If the wage of the labour in competitive market increases even by a small amount, there will be a rapid increase in the supply of the labour in that market. The elasticity of supply in such cases are infinity.

IN-TEXT QUESTION

6. Mention whether the supply will be elastic or inelastic in the following cases:
- a) Supply of perishable goods (flowers, vegetables, fruits) _____
 - b) Supply of rare drug in short run _____
 - c) Supply of sunglasses in summer season _____



- d) Supply of skilled labour in short run _____
- e) Supply of cars in long run _____

5.6 SUMMARY

An elasticity of demand represents responsiveness of quantity demanded due to change in different factors affecting demand. The Price elasticity of demand shows the percentage change in quantity demanded due to percentage change in price. The value of price elasticity of demand ranges from zero to infinity. There are various factors as determinants of elasticity of demand. These can be availability of substitute, time factors, income, etc. An elasticity of supply represents responsiveness of quantity supplied due to change in different factors affecting supply. The Price elasticity of supply shows the percentage change in quantity supplied due to percentage change in price. The value of price elasticity of supply also ranges from zero to infinity.

Elasticity of both demand as well as supply can be represented using both numerical and graphical form. The steeper the slope is, more the elasticity and flatter the slope is, less is the elasticity at a given price.

5.7 GLOSSARY

- Elasticity of Demand: The responsiveness of quantity demanded to the change in different factors causing a change in demand
- Elasticity of Supply: The responsiveness of quantity supplied to the change in different factors causing a change in supply
- Income Elasticity of Demand: The responsiveness of quantity demanded to the change in income
- Cross Price Elasticity of Demand: The responsiveness of quantity demanded to the change in price of complementary or substitute goods.

5.8 SELF-ASSESSMENT QUESTIONS

Q1) Calculate the price elasticity of demand using average method

Price	Quantity Demanded
50	250
30	320

What can you say about the elasticity?

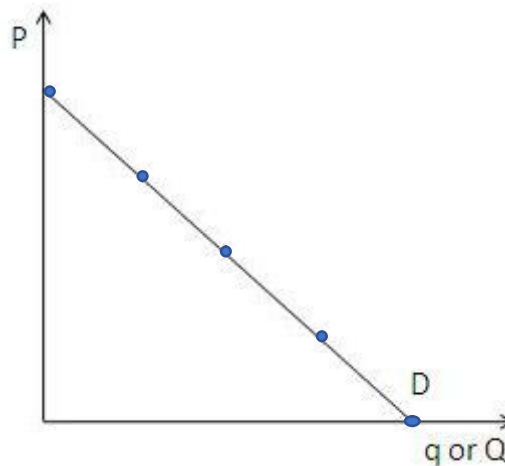


Q2) Calculate the Income Elasticity of Demand using average method

Income	Quantity Demanded
3000	20
8000	25

Comment on the value of income elasticity

Q3) Mark the value of elasticity in the different parts of the demand curve given below:



Q4) Due to climate change there was unusual rainfall in the month of November and thousands of tonnes of carrots and spinach crops were destroyed around the country. How will this impact the supply of carrot and tomatoes? Explain using the concept of elasticity of supply.

Q5) A pack of cigarette has increased from Rs 110 to Rs 170. This caused the demand to fall by 60%. What can you say about the elasticity of demand for this good? Comment on the revenue generation – will it increase or decrease? Why?

5.9 ANSWERS TO THE IN-TEXT QUESTION

- 1) a) Inelastic, b) Inelastic, c) Elastic, d) Inelastic, e) Elastic
- 2) a) False, b) False, c) True
- 3) a) Zero, b) 0 to infinity, c) Elastic, d) Steep



- 4) a) decrease, b) The demand will be elastic because now you have a substitute good available
- 5) a) Spare Capacity, b) Ease of Switching Production c) Mobility of Factors of Production
- 6) a) Inelastic, b) Inelastic, c) Elastic, d) Inelastic, e) Elastic

5.10 REFERENCES

- Mankiw, N. G. (2020). *Principles of economics*. Cengage Learning
- Pindyck, R. S., & Rubinfeld, D. L. (2014). *Microeconomics*. Pearson Education.

5.11 SUGGESTED READINGS

- Greenlaw, S. A. & Shapiro, D. (2017). *Principles of Economics 2e*. Houston, Texas. Retrieved from <https://openstax.org/books/principles-economics-2e/pages/5-introduction-to-elasticity>
- Rittenberg, L. (2011). *Economics Principles (Vol 11)*. Retrieved from <https://2012books.lardbucket.org/books/economics-principles-v1.1/index.html>
- Allen, R. G. D., & Lerner, A. P. (1934). The concept of arc elasticity of demand. *The Review of Economic Studies*, 1(3), 226-230.
- Anderson, P. L., McLellan, R. D., Overton, J. P., & Wolfram, G. L. (1997). Price elasticity of demand. *McKinac Center for Public Policy*. Accessed October, 13(2).
- Kirschen, D. S., Strbac, G., Cumperayot, P., & de Paiva Mendes, D. (2000). Factoring the elasticity of demand in electricity prices. *IEEE Transactions on Power Systems*, 15(2), 612-617.
- Andreyeva, T., Long, M. W., & Brownell, K. D. (2010). The impact of food prices on consumption: a systematic review of research on the price elasticity of demand for food. *American journal of public health*, 100(2), 216-222.



LESSON 6

PRICE AND RESOURCE ALLOCATION

STRUCTURE

- 6.1 Learning Objectives
- 6.2 Introduction
- 6.3 Understanding the Theory of Price
- 6.4 Determination of Equilibrium Price
- 6.5 Effects of Change in Supply and Demand Curve on Equilibrium Price
 - 6.5.1 Effects of Changes in Demand curve on Equilibrium Price
 - 6.5.2 Effects of Changes in Supply Curve on Equilibrium Price
- 6.4.3 Simultaneous change in Demand and Supply on Equilibrium Price
- 6.6. Market Allocation of Resources
 - 6.6.1 Price Ceiling
 - 6.6.2 Price Floor
- 6.7 Summary
- 6.8 Glossary
- 6.9 Answers to In-text Questions
- 6.10 Self-Assessment Questions
- 6.11 References
- 6.12 Suggested Readings

6.1 LEARNING OBJECTIVES

By the end of the chapter, students should be able to understand the concept of price and price mechanisms. You will also understand how the equilibrium price is determined and how the change in supply and demand affects the equilibrium price. Once you understand the functioning of demand and supply, you will be able to understand the market allocation of resources. In this chapter you will also understand the concept of price ceiling and price floor and how these concepts are used to regulate the economy.



6.2 INTRODUCTION

Before going into the deeper details of the price mechanism, let us first understand the concept of price. Price, in very simple terms, is the number of units of currency which people need to pay to buy a good or a service. Price determines the value or worth of goods and services. As we have already learnt in the previous chapter about the law of demand which says that the price of any goods and services will be determined at a point where the quantity demanded will be equal to the quantity supplied. This price is also known as the equilibrium price or market clearing price. So we can say that forces of supply and demand determine the price of any goods and services.

6.3 UNDERSTANDING THE THEORY OF PRICE

The theory of Price explains the relationship between demand and supply. This relationship determines whether the price of a commodity will rise or fall. Kahn (1984) states that, in the long run, prices are determined by the interaction between aggregate demand and aggregate supply. The consumer and supplier will try to reach the optimal point where the buyer will demand the product and be willing to pay the price, while suppliers will keep supplying the product to fulfil the demands and make profits. Consumers will keep demanding the product at the point where the price of the product will be equal to the marginal cost of producing goods and services. We have already learnt in the previous chapter about the factors which affect the demand and supply of a commodity. This relationship between demand and supply is never static. It will subsequently keep affecting the price of the commodity.

IN-TEXT QUESTION

1. State True or False
 - a) Price is the amount of a currency which one needs to pay to buy goods and services
 - b) Market Price is determined by supply only
 - c) Equilibrium Price is determined by the intersection of demand and supply
 - d) Supplier will keep supplying the product till they maximise their profit.
 - e) At the equilibrium point, the consumer will maximise their profit



6.4 DETERMINATION OF EQUILIBRIUM PRICE

The price equilibrium will be determined at the point where the quantity demanded will be equal to the quantity supplied. Any changes in demand or supply of a commodity will result in changes in its price. This can be explained with the help of an example given below:

Table 1: Quantity Demanded and Supplied at Different Price

Price unit	per	Quantity Demanded (units)	Quantity Supplied (units)	Trend	Changes in Price
50		1000	5000	Excess Supply	Price will fall
40		2000	4000		Price will fall
30		3000	3000	Demand=Supply	Equilibrium
20		4000	2000	Excess Demand	Price will rise
10		5000	1000		Price will rise

From the above table, we can understand how price determination works. When the price per unit of commodity was 50, the quantity demanded was 1000 units and quantity supplied was 5000 units. At this point, there is an excess supply. Hence, the price falls to 40 per unit. When the price reaches 30 per unit, we can see that supply is equal to demand. Therefore, the equilibrium price will be 30 per unit for both consumer and supplier.

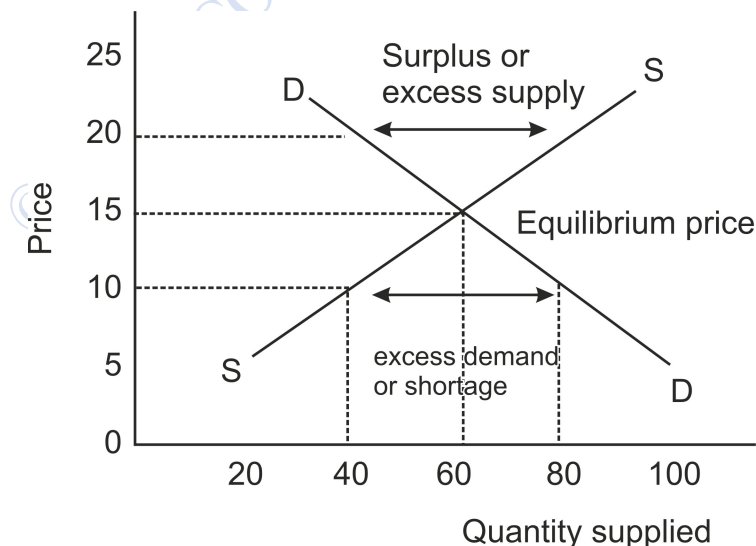


Figure 1: Excess Demand and Excess Supply



Table 1 can also be explained with the help of a graph. In figure 1 above, DD is the demand curve, and SS is the supply curve. When the price is 40 and 50, there is excess demand, and when the price falls to 10 and 20, there is excess supply. Point E is the point of equilibrium.

IN-TEXT QUESTION

2. Solve the questions

- a) Equilibrium in the marketplace means that quantity supplied Q_s equals quantity demanded Q_d . Given the following equations: $Q_s = 1.5P - 1000$ and $Q_d = 3000 - 2.5P$. Solve for the equilibrium price P . [Hint: Equate $Q_s = Q_d$ and solve for P]
- b) Market forces tend to correct excess supply and excess demand. True or False?

6.5 EFFECTS OF CHANGE IN SUPPLY AND DEMAND CURVE ON EQUILIBRIUM PRICE

Now, when we have learned how equilibrium price is determined, let us understand how price changes when the curve of supply and demand changes subsequently. There are various factors which are responsible for changes in supply and demand like changes in personal income, changes in taste and preferences, government policies, technology etc. Let us first start with understanding the effects of changes in demand on equilibrium price.

6.5.1 Effect of changes in demand curve on Equilibrium price

Let us start with the change in demand on price when there is no change in supply curve. Graphically it can be explained as

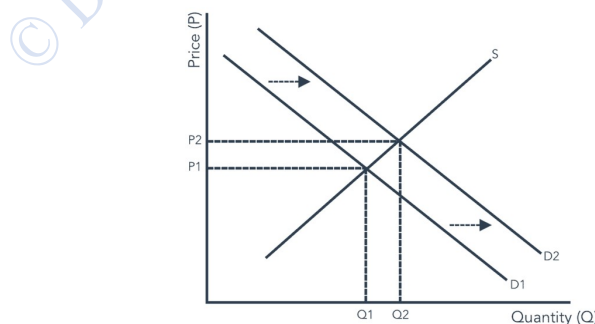


Figure 2: Change in Equilibrium Price and Quantity when Demand Curve Shifts and Supply line remains unchanged



In figure2, S is the supply curve, and D_1 is the demand curve with price P_1 and demand Q_1 . Now, suppose demand increases from D_1 to D_2 , with supply remaining constant. So, the new price will increase from P_1 to P_2 . The new equilibrium will be at a higher point where Q_2 will be the equilibrium quantity, and P_2 will be the equilibrium price. Now just reverse the scenario; suppose demand decreases from D_2 to D_1 while supply remains constant. As a result, the equilibrium price falls from P_2 to P_1 . The new equilibrium will be at a lower point. The equilibrium quantity falls from Q_2 to Q_1 .

To understand it better, let us take an example. Assume that the demand for mangoes in the summer season increases while supply remains the same. As a result, the price will also increase owing to the increase in demand. But when the demand for the same mangoes decreases, the price will automatically decrease if the supply remains constant.

Moving forward, now let us now understand the effect of changes in the supply curve on equilibrium price.

6.5.2 Effect of Changes in Supply Curve on Equilibrium Price

Now, let us understand the effect of change in equilibrium price and quantity when the supply curve shifts while the demand line remains unchanged. Figure 3 given below explains the situation.

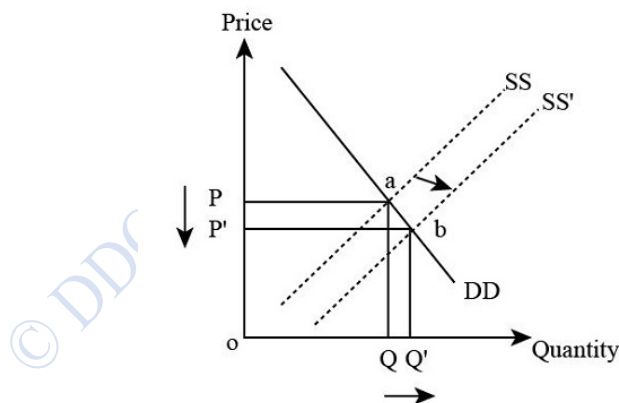


Figure 3: Change in Equilibrium Price and Quantity when Supply Curve Shifts and Demand line Remains unchanged

In the above figure, DD is the demand curve, and SS is the supply curve. The equilibrium price at this point is at OP while the equilibrium quantity is OQ. Suppose there is an increase in supply and the supply curve shifts to SS_1 , demand remaining constant. As a result, the equilibrium quantity will increase from OQ to OQ_1 , and the equilibrium price will decrease from OP to OP_1 . The new equilibrium formed will be at point E_1 .

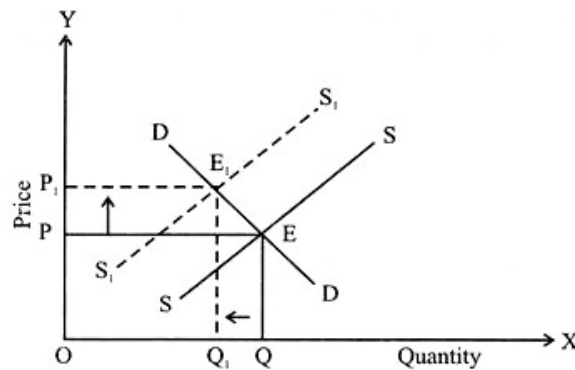


Figure 4: Change in Equilibrium Price and Quantity when Supply Curve Shifts and Demand Remains Constant

Suppose there is a decrease in supply due to a strike in the factory. Due to this, the supply curve will shift leftward from SS to S_1S_1 , while demand remains the same. As a result, the equilibrium price will increase from OP to OP_1 while the equilibrium quantity will decrease from OQ to OQ_1 .

Let us understand this with the help of an example. Assume that the production of sugar increases due to the large harvesting of sugarcanes. Now, if the demand for sugar remains the same, the price of sugar will automatically decrease. The excess supply of sugar will bring the price of sugar down. Suppose after a few months, there is heavy rainfall, and because of the flood, the sugarcane crops get destroyed. The supply of sugar decreases while demand remains the same. As a result, the price will also increase.

Let us now understand what happens when both demand and supply changes simultaneously. Figure5 below explains different scenarios where demand and supply change simultaneously.

6.5.3. Simultaneous Changes of Demand and Supply Curves on Equilibrium Price

In the previous discussions, we understood the changes in equilibrium price and quantity where either the supply or demand changes and the other remains constant. Now let us learn how the price and quantity get affected when both demand and supply change simultaneously. Here, we can have three cases:

- Demand and Supply both change by the same amount
- The increase in demand is more than the increase in supply
- The increase in supply is more than the increase in demand

Let us take all these three cases one by one.



Case I: Demand and Supply both change by the same amount

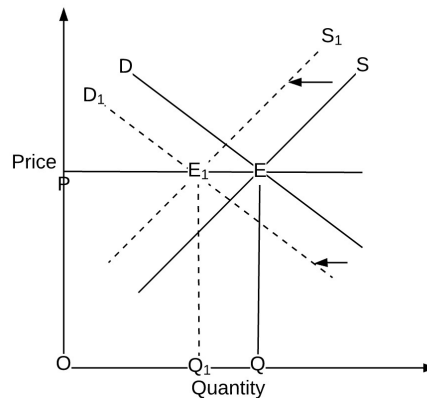


Figure 5: Simultaneous Change in Demand and Supply Curve

In the above figure, DD is the demand curve, and SS is the supply curve. E is the point of equilibrium at which OP is the equilibrium price, and OQ is the equilibrium quantity. Now, when the demand curve shifts from DD to D_1D_1 and the supply curve shifts from SS to S_1S_1 , the new equilibrium is set at E_1 . As you can see, at this point E_1 the price remains the same at OP while the equilibrium quantity has declined from OQ to OQ_1 . This happens when both the demand and supply curve shift by exactly the same amount. There is a decline in equilibrium quantity because both the demand curve and the supply curve have shifted leftward, i.e., there is a decrease in the quantity demanded as well as a decrease in the quantity supplied, leading to a decrease in the equilibrium quantity.

Let us understand this with the help of an example. Suppose the demand for umbrellas decreases in the winter season. The sellers had already anticipated this decrease in demand, and they have already started shifting their resources away from the production of umbrellas to match the decrease in demand. Thus, the decline in quantity demanded is met by an equivalent decline in the supply of umbrellas. Therefore, there will be no change in the price of umbrellas.

Case II: When the increase in demand is more than the increase in supply

In the previous discussion, the change in supply was equal to the change in demand, and as we saw that there was no change in price. Now let us learn what happens when the change in demand is more than the change in supply.

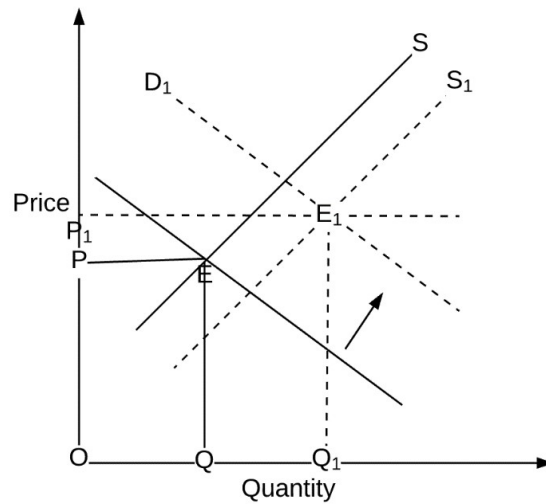


Figure6: Change in Equilibrium Price and Quantity when the Shift in Demand is more than Supply

In figure 6, D is the demand curve, and S is the supply curve. Here, E is the equilibrium point, and OP is the equilibrium price. When the demand increases, the demand curve shifts from D to D_1 . Similarly, when the supply increases, the supply curve shifts from S to S_1 . The new equilibrium point is E_1 . As we can see, when the increase in demand is greater than the increase in supply, the new equilibrium price will increase at OP_1 and the equilibrium quantity increases to OQ_1 .

Let us understand this with the help of an example. Suppose due to the outbreak of malaria, the demand for mosquito repellents increases. However, the sellers took time in catering to the extra demand for repellents, therefore there was a shortage in supply initially. Due to this shortage, the price of repellents will increase. Seeing this increased demand, more seller joins the market, and there is an increase in supply. However, in the short run, the supply is unable to match the increased demand. Therefore, the price increases.

Now, let us understand what happens if the change in supply is greater than the change in demand.

Case III: The increase in supply is more than the increase in demand

Now let us just reverse the situation that was dealt with previously. Let us try to understand changes in price and quantity demanded when the change in supply is greater than the change in demand

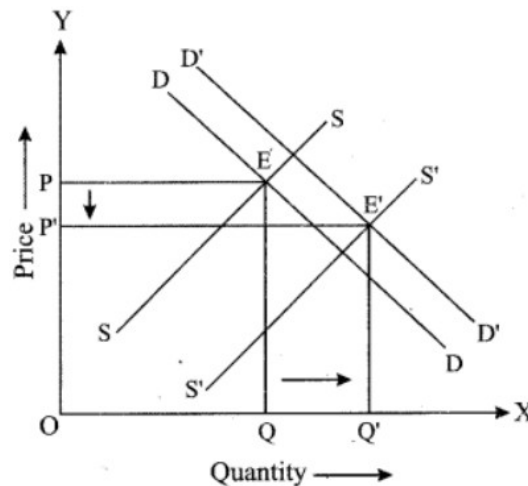


Figure 7: Change in Equilibrium Price and Quantity when the Shift in supply is more than demand

In the above figure, DD is the demand curve, and SS is the supply curve. The equilibrium is at point E, with OP and OQ being the equilibrium price and quantity, respectively. Suppose there is a change in supply and the supply curve shifts from SS to S₁S₁. This change in supply is more than the change in the demand, which shifts from DD to D₁D₁. The new equilibrium point now is E₁. At this point, the equilibrium price decreases to OP₁ and equilibrium quantity increases to OQ₁. The increase in quantity is because now there is much supply whereas the existing demand is unable to clear the stock in supply.

Let us understand this with the help of an example. Suppose a reprint of some famous book is launched in the market by a famous author. Sellers anticipated a massive demand for the book, producing many copies to be supplied in the market. However, despite some demand for the book, it was not as much as the seller anticipated. As a result, the supply has increased more than the demand, and the price has fallen while the quantity of books in the market has increased.

CASE STUDY

This case study is about the shift in India's electricity demand and supply due to changes in the macro factors. In 2019, India's annual electricity demand increased by 1.1%, the smallest rise since 2013. For the month of December 2019, power demand fell to 100.81 billion units from 101.28 billion units a year earlier, which was the fifth straight month of decline in that year. The electricity supply in the country also fell for the fifth consecutive month in December 2019. Power supply dropped down to 101.92 billion units in December 2019,



down 1.1% from 103.04 billion units the previous year. The economic slowdown, lower demand from the industrial sector, losses made by the power distribution companies, and energy efficiency measures were some of the factors responsible for the fall in power demand and supply.

Despite several months of decline in 2019, power demand grew 3.5% year on year basis and energy supply increased 3.6% year on year basis in January 2020. The higher power demand was expected to lead to a rise in power supply in the country. But the country's power demand further fell over 25% year-on-year to 125.81 gig watts in April 2020 compared to the previous year, amid the nationwide lockdown to contain the Covid-19 outbreak. For the Indian government, the challenge at hand is to manage the power sector and strike the right balance between electricity demand and supply to stimulate economic growth.

The case is structured to achieve the following teaching objectives:

1. Identify the factors responsible for the demand shift in the Indian power sector.
2. Understand how electricity demand reflects a country's economic growth
3. Discuss the shift in electricity demand and supply and its influence on the power sector

Source: ICMR (2020)

6.6 MARKET ALLOCATION OF RESOURCES

The market plays a very important role in allocating resources. This allocation is done through the price mechanism. Market resource allocation helps to understand what to produce, how to produce and for whom to produce. The price becomes the guiding principle for taking decisions regarding these three questions. Proper allocation of resources helps both consumers and producers in maximising their satisfaction. Consumers can buy those goods and services which can provide them more satisfaction and are worth their money. At the same time, producers can devote their energy and resources to produce those commodities which can bring them more profits. Since we already know that resources are limited and scarce in nature, therefore, putting the best use of them is very important for the economy. Likewise, consumers also earn a limited amount of money for their living. Therefore, they prefer to buy or acquire those goods and commodities that they need the most and can bring them the highest satisfaction. The price mechanism helps both producers and consumers in allocating their precious resources. It determines the price at which the demand and supply of



the commodity interact and the market clears, thus maintaining the equilibrium. Any deviations from the equilibrium further bring changes in its price.

For example, let us assume people have equal preference for tea and coffee when they are sold at an equal price. Now suppose production of tea, due to some reason, increases gradually. Due to the increase in supply, the price falls down for tea, and people start consuming more tea instead of coffee. This will lead to less demand for coffee and ultimately less production of coffee as well. Therefore, price becomes the factor in guiding producers in deciding what to produce so that they make efficient use of resources and maximise their profits

In a real-world scenario, it is not always the market which decides the price of a commodity. India, being a welfare country, sometimes the government has to intervene to fix the maximum as well as minimum price, considering the welfare of the people. We have two important concepts here: Price Ceiling and Price Floor. Let us understand them in detail.

6.6.1 Price Ceiling

When the prices are determined by the forces of demand and supply freely, sometimes they can rise beyond control. Under such situations, it becomes difficult for poor people to buy that commodity. Therefore, the government sometimes puts the price ceiling on some commodities that are necessary for survival. In other words, price ceiling is the price limit method that which government impose to protect it from getting too expensive or unaffordable. Controlled price helps in regulating the price in the market system. Figure 8 given below graphically explains the concept of price ceiling.

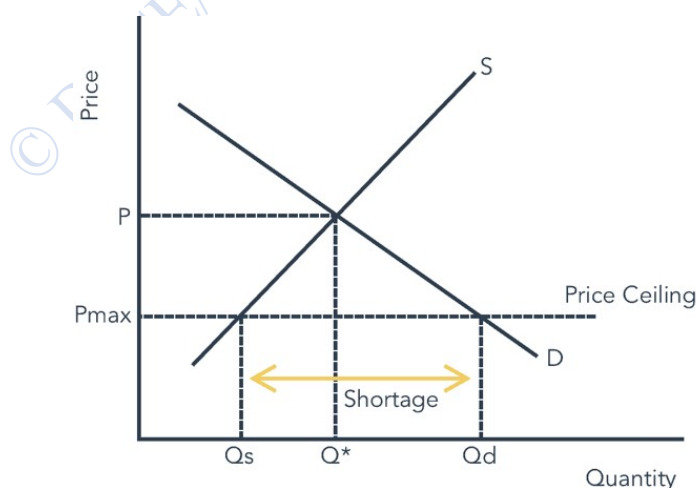


Fig 8: Price Ceiling



In the above figure, D is the demand curve and S is the supply curve. According to the market forces, the price will be fixed at P, which is the equilibrium price. However, the government wants to decrease the price and make it more affordable. If the government leaves it to the market to clear itself, it will be at price P. If, the government intervenes to put a ceiling price at P max. The price cannot increase beyond this point, which has been fixed by the government. At this price, as we can see, the demand will be more than the supply and there will be a shortage.

IN-TEXT QUESTION

3. Answer the following questions
- a. Why is there a need to control prices?
 - b. Cite two examples of goods on which price ceiling has been imposed
 - c. What is the effect of price ceiling?

6.6.2 Price Floor

Just like price ceiling, price floor is a government-induced price when it wants to limit the price of a commodity, goods or services from falling further. Sometimes the market price can get too low such that they cannot recover its production cost. Under such a situation, the government has to interfere to fix a minimum price for such products to help producers from incurring losses. For example, in India, the government has fixed prices of various crops to help farmers make some profit. Fixing the minimum wage is also an example of a price floor. Let us understand its functioning with the help of a graph.

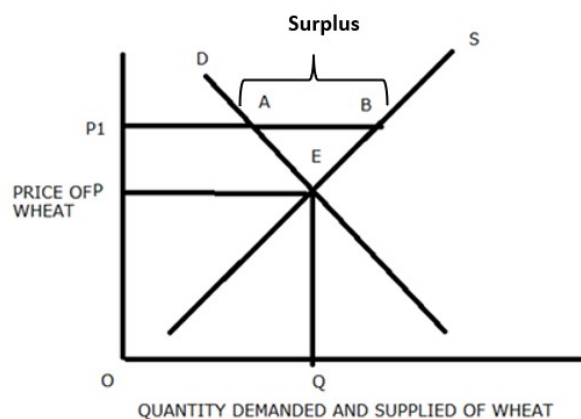


Fig 9: Price Floor



The above figure shows the demand and supply of wheat in the market. With no government interference, the price of the wheat will be fixed at P and the quantity supplied will be Q . However, this price is too low for the farmers to recover their cost of production and earn some bare minimum profit. Therefore, in order to ensure that the farmers continue the production of wheat, the government puts a price floor on the price of wheat. After the price floor, the new price is fixed at P_1 . At this price, the supply will be more than the demand and there will be surplus in the economy by AB .

IN-TEXT QUESTION

4. Answer the following questions
- Define Price Floor.
 - How are Price Ceiling and Price Floor opposite of each other

6.7 SUMMARY

Resource allocation is allocating resources for the best alternative use as the resources are scarce. The role of the market in resource allocation is to decide what to produce, how to produce and for whom to produce. Price plays an important role in the market and can be used to provide incentives to produce and ultimately allocate resources to both producers and consumers. Resources are allocated through the price mechanism in a free market economy. The economic problem of scarce resources is solved through this mechanism. However, in some situations, the government need to interfere with controlling the price through price ceiling and price floor.

6.8 GLOSSARY

- **Equilibrium-** A state where market supply and demand equate and balance each other
- **Market Forces:** Factors which affect demand and supply in the economy
- **Price Ceiling:** Government-imposed price control when the price of the commodity is too high
- **Price Floor:** Government-controlled price to set a minimum level on the price of goods and commodities in the market.



6.9 ANSWERS TO IN-TEXT QUESTIONS

<p>1. a) True b) False c) True d) Yes e) Yes</p> <p>2. a) 0.33 b) true</p> <p>3. a) To protect it from getting too expensive for poor people b) Price of life saving medicines c) The price falls below the equilibrium price</p>	<p>4. a) Price Floor is a govt. Induced price when to limit or lower the price of the commodity below the equilibrium price b) Price Ceiling is govt. Imposed price control when the price of the commodity is too high or beyond anyone's capacity to pay while Price Floor is govt.-controlled price to set a minimum level on the price of goods and commodity in the market</p> <p>Answers to Self-Assessment Questions</p> <p>1. Life-Saving drugs/Medicines, Public transport prices, Prices of Food items</p> <p>2. If the price of Coffee increase, demand for tea will increase and vice versa.</p> <p>3. Price of both tea and coffee will remain same</p> <p>4. Yes</p>
---	--

6.10 SELF-ASSESSMENT QUESTIONS

1. In India, the government tries to put a price ceiling on various commodities to deal with inflation. Make a list of all those commodities, goods and services where the government has put a price ceiling in recent times.
2. How the changes in the price of coffee will affect the demand for tea, given that both these goods are substitutes?
3. If the demand for both coffee and tea increases by the same amount, how it will affect their price?
4. Minimum wage policy of the Indian government is an example of a price ceiling or price floor? Explain how it impacts the labour market.
5. Graphically draw the equilibrium point for the following table:



Price per unit	Quantity Demanded	Quantity Supplied
500	10000	50000
400	20000	40000
300	30000	30000
200	40000	20000
100	50000	10000

6.11 REFERENCES

- Pindyck, R. S., & Rubinfeld, D. L. (2014). *Microeconomics*. Pearson Education.
- Frank, R. H., & Cartwright, E. (2010). *Microeconomics and behaviour* (Vol. 8). New York: McGraw-Hill.

6.12 SUGGESTED READINGS

- Kahn, G. A. (1984). International differences in wage behaviour: real, nominal, or exaggerated?. *The American Economic Review*, 74(2), 155-159.
- ICMR (2020). *Electricity Sector in India: Coping with Changes in Demand and Supply*. ICM Research. Retrieved from [Electricity Sector in India: Coping with Changes in Demand and Supply|Economics|CaseStudy|Case Studies \(icmrindia.org\)](http://icmrindia.org)



LESSON 7

TRADE & WELFARE

STRUCTURE

- 7.1 Learning Objectives
- 7.2 Introduction
- 7.3 How Trade Increases Welfare?
- 7.4 Determinants of International Trade
 - 7.4.1 Equilibrium without Trade
 - 7.4.2 Equilibrium with Trade
- 7.5 Winners and Losers from Trade
 - 7.5.1 Gains & Loses of an Exporting Country
 - 7.5.2 Gains & Loses of an Importing Country
- 7.6 The Case of Tariff
- 7.7 Summary
- 7.8 Terminal Questions
- 7.9 Glossary
- 7.10 References

7.1 LEARNING OBJECTIVES

Following completion of this unit, students will be able to:

1. Compare the equilibrium outcomes for the country with and without international trade.
2. Determining the winners and losers of international trade.
3. Analyzing the impact of tariff on a good.
4. Understanding the benefits of international trade.
5. What are some common arguments for restricting trade?

7.2 INTRODUCTION

In recent times, world has become a global marketplace. Students might be using wireless phones manufactured in Korea or enjoying the dinner that includes fruits from Mexico or Chile. The likelihood is high that a sizable amount of your employer's sales—and therefore



the money used to pay your salary—comes from export sales if your employment as an employee involves farming, machinery, vehicles, or many other technology-related businesses. Thus, we are all linked with international trade. Trade is the term used to describe the exchange of goods and services, and when it occurs between nations, it is referred to as international trade. In this unit, we will be studying the standard demand and supply tools to understand the trade mechanism between two countries and will also analyze the policy options exercised to restrict the trade among countries.

7.3 HOW TRADE INCREASES WELFARE?

Trade refers to voluntary exchange of goods and services. Individuals who engage in trade must be willing to give up something in return for a good or service. Therefore, individuals will be willing to trade if they get benefits from exchange. This exchange process will not happen if one of the trading partners believed that they are not getting any gains from this exchange. Trade can take place between two individuals, regions, or nations. This raises a question: Why do individuals trade? The answer is trading takes place between individuals, companies, and nations because one party has an item you desire. You either need or want something that someone else possesses. Resources, both natural and human, are not distributed equitably across the world or even inside a single country. Redistributing resources from those who value them less to those who value them more is one of trade's most significant roles.

Trade that takes place between individuals is termed as interpersonal trade. Trade between individuals allows people to specialize in those services/goods that they can perform reasonably effectively and to purchase from others those goods and services that they are unable to easily produce. Similarly, when trade takes place between two regions or two nations it is referred to as inter-regional trade and international trade respectively.

According to the economist Gregory Mankiw, “Trade allows each person to specialize at what he or she does best”. Thus, international trade helps each nation to achieve specialization. Trade allows each region or nation to focus on producing those goods and services that can be produced efficiently with the available resources and trade for those goods and services in which it is less efficient. Unit 3 discusses about how trade is based on absolute and comparative advantage. In the next section we will examine how nations trade with each other.



7.4 DETERMINANTS OF INTERNATIONAL TRADE

Let us consider the market for wheat grain. Wheat is grown in many parts of the world and there exist much trade in this commodity. In recent years, there has been many trade restrictions imposed on the trade of wheat grain in order to protect domestic consumer demand needs. In this section, we will look into how trade impacts the price and quantity of wheat grain sold in the domestic market and who gains or losses from the trade?

7.4.1 Equilibrium without Trade

Let us suppose there is an imaginary Country A producing wheat. By government order, no person in country A is allowed to trade with other countries. With no international trade, the domestic market for wheat in this country consists of the local buyers and sellers. From Figure 8.1, the equilibrium price is attained where the quantity supplied by domestic sellers equals the quantity demanded by the domestic buyers (point E). The equilibrium price are P and Q respectively. The figure depicts the consumer surplus (the area below the demand curve and price line P) and producer surplus (the area above the supply curve and the price line P) in equilibrium without trade.

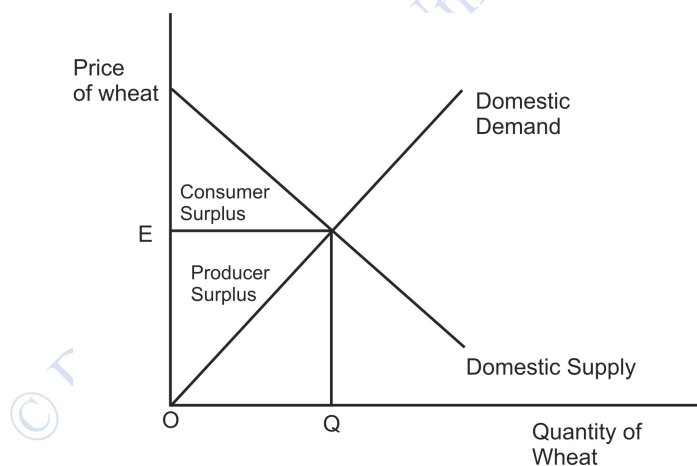


Figure 8.1: Equilibrium without Trade

7.4.2 Equilibrium with Trade

Suppose the government in Country A allows international trade with other countries of the world. This raises an issue among the policymakers, whether Country A should become importer or exporter of the wheat grain. Alternatively, if there exist free trade, will the residents of Country A end up in selling or buying in the world market for wheat?



To review this situation, the policymakers will first compare the price of wheat prevailing in Country A (domestic price) to the price of wheat in other countries. Let us assume that the price prevailing in the world market is called as the **world price**. Before trade, while comparing the world price and domestic price, the policymakers take the following decisions:

1. If the world price is higher than the domestic price, then Country A will export wheat in other countries.
2. If the world price is lower than the domestic price, then Country A will import wheat in other countries.

This exercise of comparing prices by the policymakers reflects whether Country A has comparative advantage in producing wheat or not. The price prevailing in the domestic market indicates the opportunity cost of wheat. If say, domestic price is low, then it means that cost of producing wheat in Country A is lower, suggesting that it has a comparative advantage in producing wheat in relation to the rest of the world. Alternatively, if domestic price is high, then Country A has a higher cost of producing wheat and other countries have a comparative advantage in producing the wheat.

From the previous Chapter 4, we have seen that countries trade with each other on the basis of comparative advantage. Trade allows each country to specialize in the product that can be produced best. With this comparison of price and decision to become exporter or importer we will now look at the benefits of trade in the next section.

IN-TEXT QUESTION

1. Suppose in Country A, the price of wheat before trade is \$1000 per tons. In neighboring Country B, the same wheat can be bought with \$800 per tons. If free trade is allowed between the two countries, will Country A import or export wheat?

Answer. Country A will import wheat as price of wheat prevailing in Country B is lower than that of price in Country A.

7.5 WINNERS AND LOSERS FROM TRADE

To understand the welfare effects of trade, let us make an assumption that Country A is a “*small economy*” relative to the rest of the world. By the *small economy* assumption, we meant that Country A has very small influence or no influence on the world markets. More specifically, any change in the domestic or trade policy of Country A will have no impact on the world prices. In other words, they are the price takers in the world market. Though small-



economy assumption is not necessary for analyzing the gains from trade, we made this assumption in order to simplify the understanding.

7.5.1 Gains & Loses of an Exporting Country

As discussed in the previous section, Country A will be exporting wheat to Country B, when domestic price is lower than the world price. If free trade is allowed and Country A becomes exporter, then in that case the domestic price prevailing in the economy increases and becomes equal to the world price. In this situation, no buyer is willing to pay more than the world price and no seller will accept price less than the world price. With the increase in the domestic price, differences arise between domestic quantity supplied and domestic quantity demanded.

Figure 8.2 depicts the case of an exporting country. The supply curve in the diagram shows the quantity of wheat produced domestically, while the demand curve represents the quantity consumed in the Country A. The horizontal line in the diagram depicts the world price. This line can be viewed as the demand curve of the rest of the world. It is perfectly elastic because of our small-economy assumption for Country A that is it can sell as much quantity of wheat in the market as it desires at the world price.

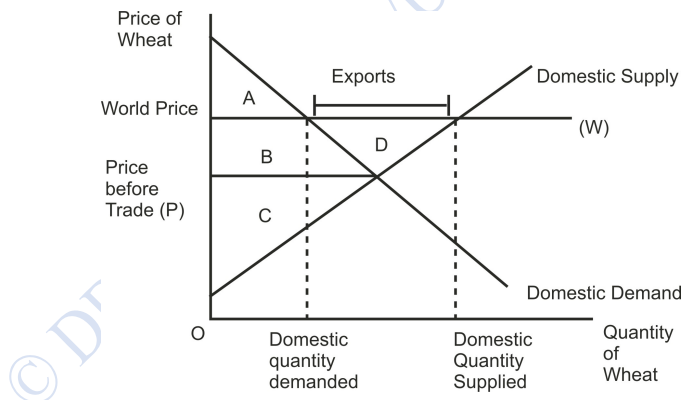


Figure 8.2: Trade in Exporting Country

Table 8.1: Welfare Effects of Exporting Country

	Consumer Surplus	Producer Surplus	Total Surplus
Before Trade	A+B	C	A+B+C
After Trade	A	B+C+D	A+B+C+D
Change	-B	+(B+D)	+D



To understand the gains and losses from the trade, let us examine the Table 8.1. After allowing trade for Country A, the domestic price rises to the world price which benefits the domestic sellers as they could now sell wheat at higher price in the market. Whereas the domestic consumers lose out as they have to buy the wheat at the higher price. These gains and losses are measured through changes in consumer and producer surplus. Before trade, the equilibrium price in Country A is P . The consumer surplus before-trade is area $A+B$, representing the area between the price P and the domestic demand curve. Similarly, the producer surplus before-trade is area C , the area between price P and the domestic supply curve. The total surplus before trade is computed by summing the producer and consumer surplus, area $A+B+C$.

With trade, the domestic price P of the wheat changes and becomes equal to world price W . This results in a change in both the consumer and producer surplus. The consumer surplus shrinks to area A (the area between W and domestic demand curve) and producer surplus expands to area $B+C+D$ (the area between W and domestic supply curve). After trade is being allowed, the total surplus of the Country A becomes $A+B+C+D$.

From these calculations, the winners and losers of trade can be ascertained. In this case, Country A was exporting wheat to Country B. The domestic sellers benefit from trade as their surplus increases by area $B+D$ (the change column), while the domestic consumer's lose out as their surplus reduces by area B . However, the total surplus increases by area D , *suggesting that the gain from the trade exceeds the losses*. The area D reflects the increase in economic well-being of the country due to trade or the gains from trade.

From the above analysis, if a country becomes exporter of the good, then:

1. The domestic producers benefit from the trade, while the domestic consumers are worse off.
2. Trade between countries increases the economic well-being as the gains from the trade exceed the losses.

7.5.2 Gains & Losses of an Importing Country

Suppose that the world price is lower than the domestic price. In this case, if trade is allowed then Country A will be now importing wheat to Country B. The domestic price will change to become equal to the world price.

Figure 8.3 depicts the case of an importing country. The supply curve in the diagram shows the quantity of wheat produced domestically, while the demand curve represents the quantity consumed in the Country A. The horizontal line in the diagram depicts the world price. In this



case, the line can be viewed as the supply curve of the rest of the world. It is perfectly elastic because of our small-economy assumption for Country A that is it can purchase as much quantity of wheat in the market as it desires at the world price.

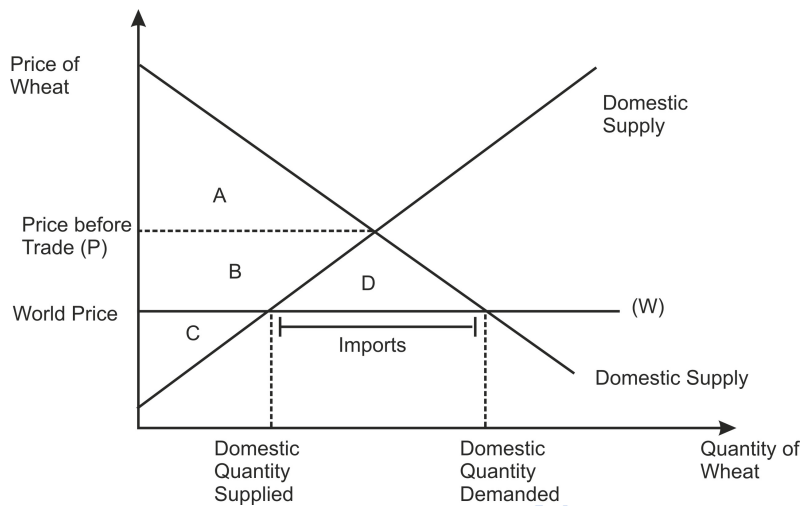


Figure 8.3: Trade in Importing Country

Table 8.1: Welfare Effects of an Importing Country

	Consumer Surplus	Producer Surplus	Total Surplus
Before Trade	A	B+C	A+B+C
After Trade	A+B+D	C	A+B+C+D
Change	+(B+D)	-B	+D

To understand the gains and losses for the importing country, let us examine the Table8.2. After allowing trade for Country A, the domestic price falls to the world price which benefits the domestic buyers as they could now buy wheat at a lower price in the market. Whereas the domestic sellers will lose out as they have to sell the wheat at a reduced price. These gains and losses are measured through changes in consumer and producer surplus. Before trade, the equilibrium price in Country A is P. the consumer surplus before-trade is area A, representing the area between the price P and the domestic demand curve. Similarly, the producer surplus before-trade is area B+C, the area between price P and the domestic supply curve. The total surplus before trade is computed by summing the producer and consumer surplus, area A+B+C.



With trade, the domestic price P of the wheat changes and becomes equal to world price W . This results in a change in both the consumer and producer surplus. The consumer surplus expands to area $A+B+D$ (the area between W and domestic demand curve) and producer surplus shrinks to area C (the area between W and domestic supply curve). After trade is being allowed, the total surplus of the Country A becomes $A+B+C+D$. With a reduction in the domestic price, a difference arises between domestic quantity supplied and domestic quantity demanded, and this difference in demand is imported from Country B.

From these calculations, the winners and losers of trade can be ascertained. In this case, Country A is importing wheat to Country B, the domestic consumers benefit from trade as their surplus increases by area $B+D$ (the change column), while the domestic sellers loose out as their surplus reduces by area B . However, the total surplus increases by area D , *suggesting that the gain from the trade exceeds the losses*. The area D reflects the increase in economic well-being of the country due to trade or the gains from trade.

From the above analysis, if a country becomes importer of the good, then:

1. The domestic consumers benefit from the trade, while the domestic suppliers are worse off.
2. Trade between countries increases the economic well-being as the gains from the trade exceed the losses.

The analysis of the welfare effects of trade between two countries further strengthens our understanding of the Ten Principles of Economics: “*Trade makes everyone better off*”. In either case, if Country A becomes an exporter or importer of wheat, the gains from trade will make everyone better off. However, in our analysis, we have shown that the winners of the trade will compensate the losers. But in practice, there exist hardly any compensation mechanism. Thus, there is always a debate whether countries should allow for free trade or not. In the next section, we will be examining the impact of trade policies on welfare outcomes.

IN-TEXT QUESTION

2. When trade is allowed and nation chooses to import a good, then in that case:
 - i. Both producer and consumer surplus increases.
 - ii. Producer surplus decreases but consumer surplus increases.
 - iii. Producer surplus increases but consumer surplus falls.



- iv. There is no change in consumer and producer surplus.

Answer: ii

7.6 THE CASE OF TARIFF

Trade policy of a country is often driven by the desire to protect its domestic industry and workers from foreign competition as imports are usually available at cheaper prices in comparison to their domestic counterparts. In many cases, cheaper imports create a stiff competition for domestic firms which result in large number of job losses for domestic workers. In such scenario, the policy makers take preventive measures in the form of direct price controls such as tariff to quotas, voluntary export restraints and others. In this section, we will focus on one of the forms of trade policy: **tariffs**. A tariff is a trade restriction in the form of tax which is imposed on the imported goods. If Country A decides to become importer of the wheat, then in that case the imposition of tariff will be effective. If Country A is exporting the commodity, then a tax on wheat imports is irrelevant.

Consider a situation where the policymakers of Country A decide to impose a tariff on wheat imports. The imposition of tariff will have welfare effects and thus we will compare these effects with and without the tariff. From Figure 8.4, with free trade, the domestic price of wheat equals the world price P' . However, a tax on imported good would increase the price of wheat above the world price by the amount of tariff and becomes P_T . As a result, the domestic suppliers can now sell wheat for the price equivalent to the amount of tariff plus the world price and can easily compete with their foreign counterparts. This change in price will affect the domestic supply and demand behavior. With the imposition of tariff, the price of wheat rises which leads to a reduction in domestic demand for wheat from OQ_1 to OQ_2 but increase the domestic supply from OQ_3 to OQ_4 .

Both domestic buyers and sellers are affected by the tariff on wheat imports. The gains and losses associated with tariff can be assessed through changes in producer surplus, consumer surplus and government revenue. From table 8.3, before the imposition of tariff the consumer surplus equals to area $A+B+C+D+E+F$, the area between the domestic demand curve for wheat and P' (world price). While, the producer surplus is represented by the area G , which is the area between domestic supply curve and P' . Under free trade, since there is no government intervention, the revenue of the government equals zero. The total surplus before tariff will equal to the area $A+B+C+D+E+F+G$, sum of consumer and producer surplus.

With the introduction of tariff by policymakers in Country A, the domestic price changes and becomes P_T (including world price plus the amount of tariff). With this rise in price, domestic



demand declines and the consumer surplus shrinks to an area A+B, the area between P_T and domestic demand curve, and that of producer surplus increases to area C+G. Since tariff is in the form of tax, the government will also receive revenues from its imposition. This revenue equals to the amount of tariff ($P_T - P'$) times the quantity of wheat imported (Q_4Q_2) the area E. The total surplus becomes A+B+C+E+G after tariff. Looking at the last row of Table 8.3, we find that the consumer surplus has declined by area C+D+E+F, producer surplus increases by the area C and additional government revenue is generated by area E. However, there has been a decline in total surplus by the area D+F.

This area D+F represents the deadweight loss of the tariff. As discussed in the Chapter on Taxation, the imposition of a tax generates a deadweight loss. Since, tariff is also a form of tax on imported goods; it will distort incentives in the market and does not lead to optimum outcomes. In our analysis, the tariff generates two effects (represented as triangular area D and F) that alter the market outcomes:

- 1. Deadweight loss from overproduction of good (area D):** with the imposition of tariff the domestic price rises above the world price, which gives an opportunity to the domestic suppliers to increase the supply of wheat from OQ_3 to OQ_4 .
- 2. Deadweight loss from under-consumption of good (area F):** the increase in price after tariff encourages the domestic consumers to reduce the demand for wheat, which falls from OQ_1 to OQ_2 .

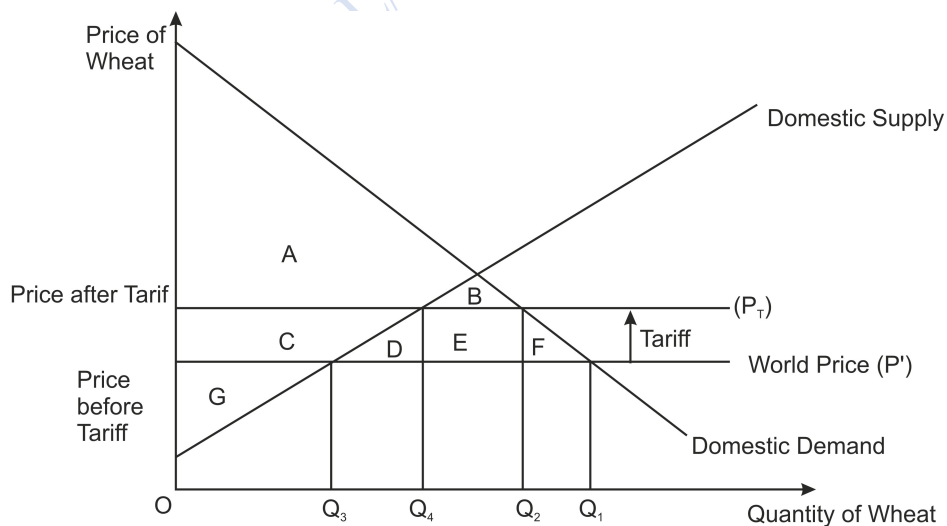


Figure 8.4: Tariff Imposed by an Importing Country



Table 8.3: Welfare effects of Tariff

	Consumer Surplus	Producer Surplus	Government Revenue	Total Surplus
Before Tariff	A+B+C+D+E+F	G	NIL	A+B+C+D+E+F+G
After Tariff	A+B	C+G	E	A+B+C+E+G
Change	-(C+D+E+F)	+C	+E	-(D+F)

We can also solve the case of tariff mathematically through the following example:

Example: Suppose Country A is producing and consuming apples. The world price of the apples is ₹ 1 per unit and the domestic demand and supply of the apples is given as:

Demand: $Q = 8 - P$

Supply: $Q = P$, where P is the domestic price of the apples. If the policymaker in Country A imposes a tariff ₹ 1 per unit on the imported apples, then the welfare of both producers and consumers will change. In this example, we will compute the welfare effects without trade, with trade and after the imposition of tariff. We will also determine the deadweight loss of the tariff.

Case I: When no trade is allowed

In this case, the equilibrium price and quantity will be determined where domestic demand equals domestic supply. Hence,

Demand=supply

$$8 - P = P$$

$$8 = 2P$$

$P=4$, inserting the value of P in demand equation we get $Q=4$. For measuring welfare, we need to calculate the consumer and producer surplus. If we plot these equations, then for demand curve if $Q=0$ we will get price equals to 8. While the supply curve is increasing starting from origin with $Q=0$ then $P=0$.

From the Figure 8.5, the area of consumer surplus is the area of the triangle APE which is $\frac{1}{2} \times \text{Base} \times \text{Height}$. Thus,



Consumer Surplus= $\frac{1}{2} \times 4 \times (8-4) = 8$

Producer Surplus= $\frac{1}{2} \times 4 \times (4-0) = 8$ Total Surplus= $8+8=16$

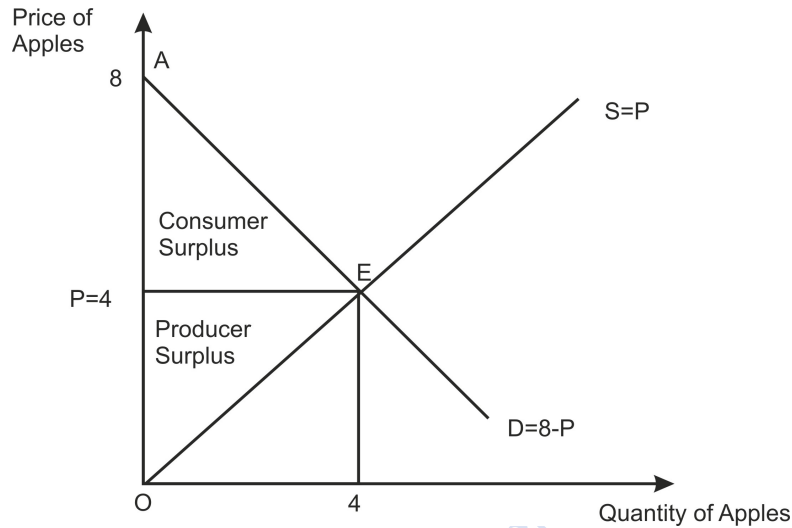


Fig 8.5

Case II: When trade is allowed

After trade is allowed, then domestic price becomes equals to world price and thus will decline to ₹ 1. With this new price, domestic demand now becomes

Demand= $8-1=7$ units, while the Supply= 1 units. Thus, there is an excess demand for 6 units. At this price consumer surplus will increase while producer surplus will decline. From Fig 8.5,

Consumer Surplus= area of triangles (A, B, C, D, E, F) = $\frac{1}{2} \times 7 \times (8-1) = 24.5$

Producer Surplus= area of triangle G= $\frac{1}{2} \times 1 \times (1-0) = 0.5$ Total Surplus= $24.5+0.5=25$

Clearly, after trade total surplus of the country has increased.

Case III: Imposition of Tariff

After tariff, the domestic price equals to $1+1$ (tariff rate) = 2. At this new price, demand is $8-2=6$ units and supply are 2 units. Thus the 4 units (6-2) are being imported. Additionally, the government also gets revenues from tax on imports. The welfare indicators are:

Consumer Surplus = area (A+B) = $\frac{1}{2} \times 6 \times (8-2) = 18$

Producer Surplus= area (C+G) = $\frac{1}{2} \times 2 \times (2-0) = 2$



Government revenue= area of square E= $(2-1) \times 4 = 4$

Total Surplus= $18+2+4=24$. Clearly, there is a decline in total surplus after tariff is being implemented.

Deadweight loss is area of triangles D and F

Area of D= $\frac{1}{2} \times (2-1) \times (2-1) = 0.5$ and Area of F= $\frac{1}{2} \times (7-6) \times (2-1) = 0.5$

So total deadweight loss is $0.5+0.5= 1$

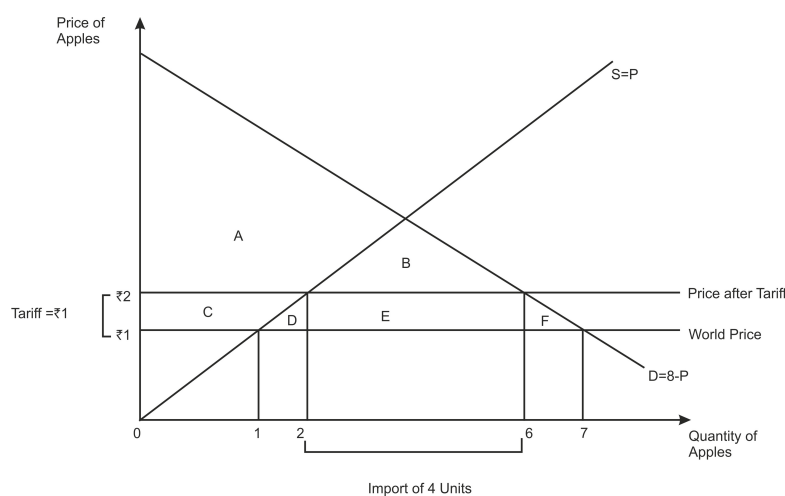


fig 8.6

7.7 SUMMARY

In this unit, we learned about the impacts of free trade on an economy through the comparison of domestic price and the world price. If the domestic price is lower in the country, then it enjoys the comparative advantage in a good or service and thus becomes an exporter of the good. Whereas, if domestic price is higher, then foreign producers have a comparative advantage and thus, the domestic country becomes an importer. In both cases, either the domestic producers or consumers become the winners or losers from trade. In the case when a country exports the good, domestic producers benefit while the consumers lose out. On the contrary, in the case of importing country domestic consumers are better off while the producers became worse off. However, trade in both cases results in gains exceeding the losses.

Despite the gains from trade, we also looked into the trade restrictions in the form of tariff on imported goods. The welfare impact of tax on imported good results in a deadweight loss for



an economy with losses from exercising this policy leads to losses exceeding the gains. Finally, we discussed the various arguments for restricting trade, with some having strong merits while others suffer from politics and lobbyists actions.

7.8 TERMINAL QUESTIONS

1. The world price of sugar is below the price prevailing in India in the absence of trade.
 - i. If India is a small economy and is importing sugar, sketch the graph under free trade conditions. Show the consumer surplus, producer surplus and total surplus in that graph. Also, depict changes before and after trade in a table.
 - ii. Suppose there is a change in world price of sugar such that it becomes higher than the price prevailing in the Indian economy before trade. In this situation what will India do? Depict these changes in a graph with consumer, producer, and total surplus. Also, depict changes before and after trade in a table.
2. Describe what a tariff is and explain its economic effects.
3. List the arguments given to support trade restrictions. What are the criticisms associated with it.

7.9 GLOSSARY

Specialization, Gains from trade, Trade policy, protectionism, and tariff

7.10 REFERENCES

- Mankiw, N. G. (2018). Principles of Microeconomics 8th Ed. Pearson
- Frank, R. H., & Cartwright, E. (2010). Microeconomics and behavior. New York: McGraw-Hill.



LESSON8

TAXATION

STRUCTURE

- 8.1 Learning Objectives
- 8.2 Introduction
- 8.3 Importance of taxation
- 8.4 Effect of Taxes on Market Outcome
 - 8.4.1 Deadweight Loss or Market Inefficiencies
 - 8.4.2 Incidence of Taxes, if Taxes are Levied on Sellers
 - 8.4.3 Incidence of Taxes if Taxes are Levied on Buyers
 - 8.4.4 Incidence and Elasticity
- 8.5 Laffer Curve
- 8.6 Summary
- 8.7 Answer to Intext Questions
- 8.8 Self-Assessment Questions
- 8.9 References

8.1 LEARNING OBJECTIVES

This lesson will explain students the following concepts :

1. Importance of taxation since ancient era.
2. Effects of taxation on the market outcomes.
3. How taxes create deadweight loss and market inefficiencies.
4. Incidence of taxes whether levied on buyer or on seller.
5. Difference between impact and incidence of taxation.
6. Optimal taxes rate through Laffer curve.

8.2 INTRODUCTION

Taxes are one way payment to the government from individuals & other agents. There is no “quid -pro- quo”. In ancient era taxes were collected in the form of a portion of crop produce, forest produce, taxes on mining metals, trade etc.



In the previous chapter you have read about market and understood its importance in determination of equilibrium prices and quantity. Imposition of taxes fluctuates market outcomes and create market inefficiencies.

As you know that taxes create market inefficiencies. So, the most important question arises who bears the burden of taxes. Does seller bear all the tax burdens or buyer bears all the tax burden.

In this chapter you will learn about importance of taxation, its effects and how it creates market inefficiency. You will study impact and incidence of taxation, Impact of elasticity of demand and supply on incidence and at last you will read about Laffer curve and its importance in determining the optimal tax rate.

8.3 IMPORTANCE OF TAXATION

Taxes are collected by the states to meet its expenditure on governance. It is the role of the state to maintain law and order, defense, governance, and welfare of the masses. Kautilya had rightly said that “government is run not on emotions but on tax revenue collections”. State run various schemes to uplift the poorer section and needy. All this require revenue which are collected by the subjects of the state.

Certain taxes are levied to discourage the production and consumption of certain goods such as cigarettes, tobacco, or petrol etc.

8.4 EFFECT OF TAXES ON MARKET OUTCOMES

Market demand and supply interact in the market to determine the equilibrium price and quantity. Imposition of taxes affects the market equilibrium level of price and quantity. Taxes discourages production and consumption and creates market inefficiencies.

8.4.1 Deadweight Loss or Market Inefficiencies

Suppose the demand and supply intersect at equilibrium price of ₹5. Area A+B+C is consumer surplus. D+I+F is producer surplus. The government imposes tax ₹ 4 on ice cream.

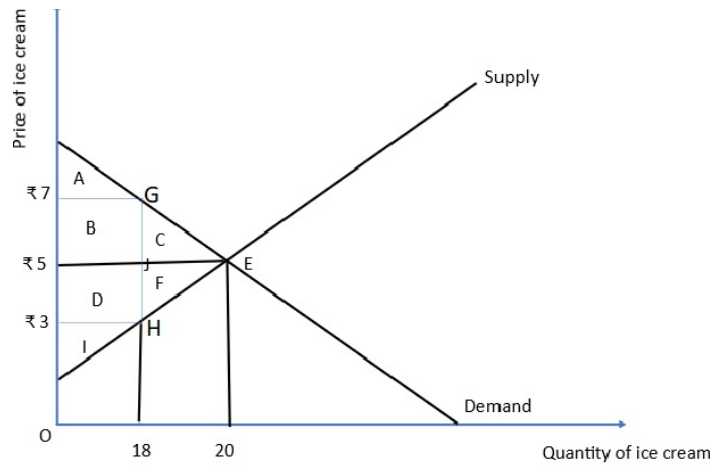


Figure1: Effect of imposition of tax

This creates a wedge equals to GH, which is tax of ₹4 at per unit of ice cream. Now, with tax, a buyer has to spend more money to buy a unit of ice cream. The buyer pays ₹7 whereas, seller receives ₹3 for a unit of ice-cream.

Earlier there were some buyers whose willingness to pay for the ice-cream was ₹6 whereas, the price of ice-cream was ₹5. So, they had consumer surplus, but now they will not buy the ice-cream as the price of ice-cream is greater than their willingness to pay.

So, the loss of consumer and producer due to tax and loss of output i.e., earlier 20 units of output used to be produced but with the imposition of taxes only 18 units are produced. So, this loss of C+F is dead weight loss in society.

	Before tax	After tax
Consumer surplus	A+B+C	A
Producer surplus	D+F+I	I
Tax revenue	0	B+D
Total	A+B+C+D+F+I	A+B+D+I
Change		-(C+F)

So, the lost production and consumption due to the imposition of taxes creates market inefficiency or deadweight loss to society.



8.4.2 Incidence of Taxes, if Taxes are Levied on Sellers

Suppose government passes a law of paying taxes by the producer on the production of petrol per unit.

Imposition of tax will affect the supply and demand is unchanged and new equilibrium is E' with new price of ₹ 10 per unit. At old equilibrium price per unit was ₹ 8 per unit. With the imposition of tax, seller receives ₹ 7 per unit. With the increase in price of petrol per unit the quantity falls from 100 to 90 units. Seller receives lower price for their products.

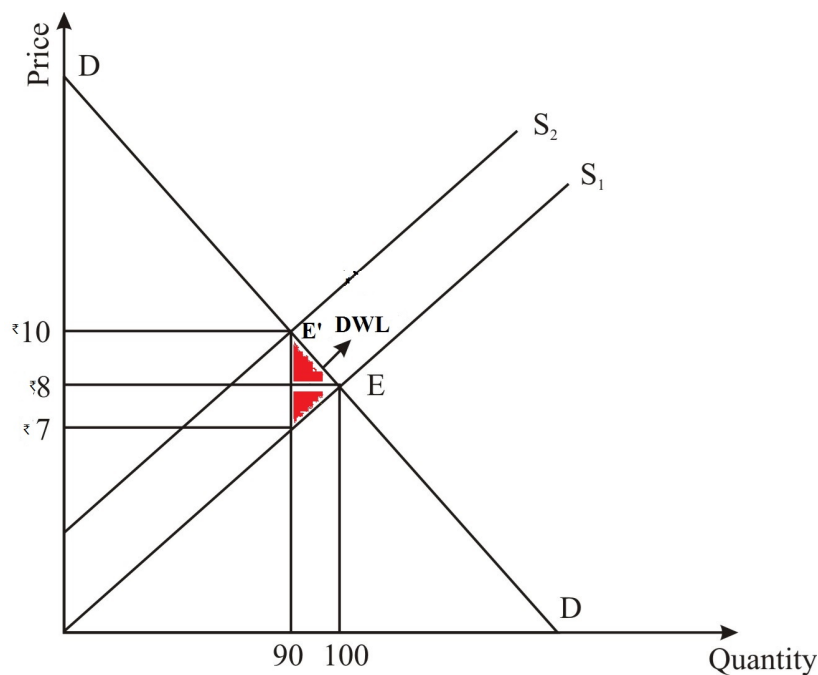


Figure 2: Impact of tax on seller

So, the impact of tax is on the producer, but incidence is shared by buyer and seller.

8.4.3 Incidence of Taxes if Taxes are Levied on Buyers

Now, if the government imposes new rule and penalties on all those who consume petrol. To discourage the consumption of Petrol, government decides to impose tax of ₹ 3 per unit on petrol.

Since the impact of the tax is on the buyer. So, demand of the petrol shifts to the left and supply remains unchanged. The old equilibrium is E with the price of ₹ 8 and quantity of 100



units. With the new equilibrium E' the buyers pay ₹ 10 for the purchase of petrol and seller receives ₹ 7.

With the increase in prices per unit the quantity falls from 100 units to 90 units.

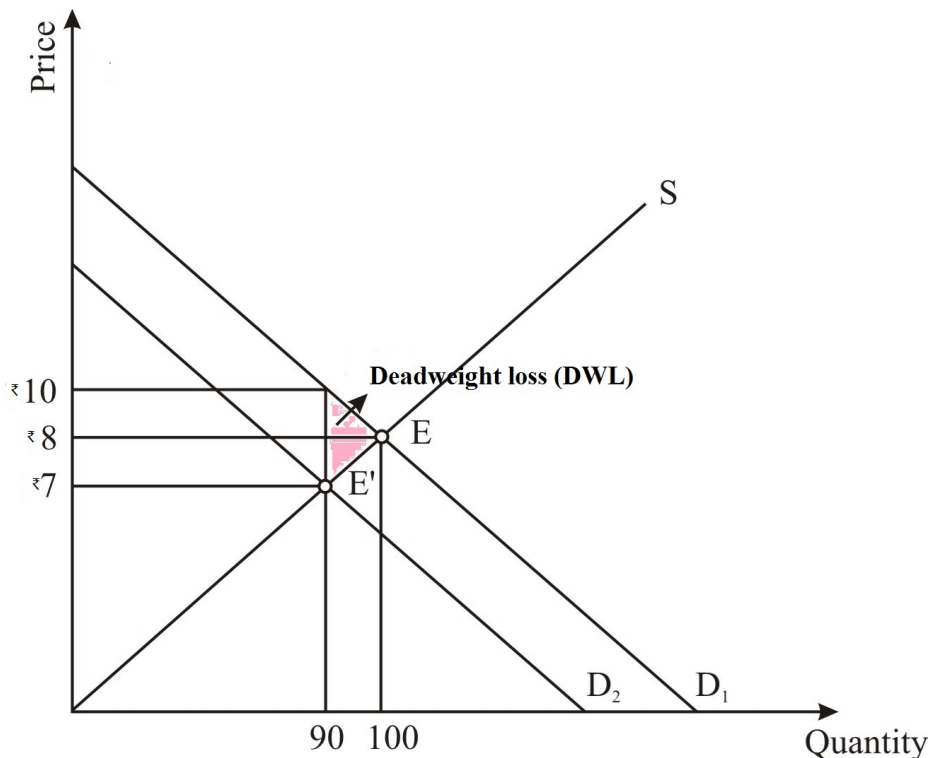


Figure 3: Impact of tax on buyer

So, the impact of tax falls on the buyer, but incidence is shared by both buyers and seller.

This imply that whether the tax is imposed on buyer or on the seller, the incidence of tax is shared by both buyers and sellers.

IN-TEXT QUESTIONS

1. When a tax is collected from the buyer then _____ also bears the burden of tax.
2. Within the demand Supply Model, tax collected from buyer shifts the _____ curve to the left.
3. Due to the imposition of tax, quantity sold _____.



4. Due to the buyer imposition of a tax, price paid by the buyer _____.
5. With the imposition of a tax, price received by the Seller _____.

8.4.4 Incidence and Elasticity

As in the previous section we have learnt that incidence of tax falls on both buyers and seller. It does not matter whether the tax is levied on buyer or seller as it is shared by both. Now the question arises who bears most of the burden, or who bears less. What factors decide the distribution of tax burden between the buyer and seller? The answer is the elasticity of demand and supply determine the burden shared by buyer and seller.

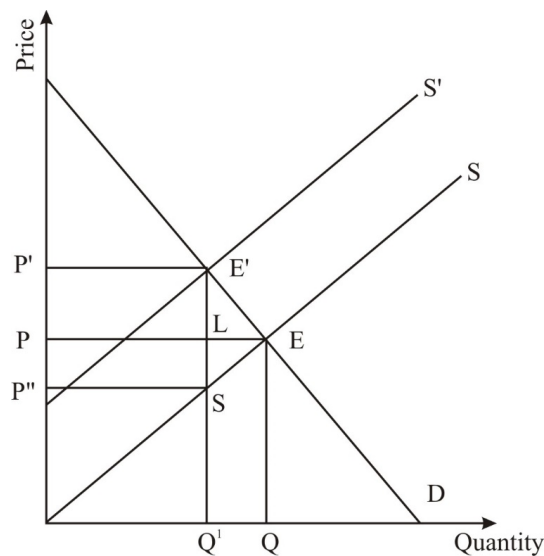


Figure 4: Incidence of taxation

Here $\frac{E'L}{LS} = \frac{\text{Incidence of tax on buyer}}{\text{Incidence of tax on seller}}$

As given from the previous chapter

Elasticity of demand =

$$\frac{\Delta q}{\Delta p} \times \frac{p}{q}$$

Change in quantity is QQ' and change in price is P to P' or LE.



$$ed = \frac{QQ'}{LE'} \times \frac{OP}{OQ}$$

Similarly, elasticity of supply = $\frac{dq}{dp} \times \frac{P}{q}$

$$= \frac{QQ'}{LS} \times \frac{OP}{OQ}$$

Change in quantity is QQ' and change in price is P to P'.

$$\frac{ed}{es} = \frac{\frac{QQ'}{LE'} \times \frac{OP}{OQ}}{\frac{QQ'}{LS} \times \frac{OP}{OQ}}$$

$$\frac{ed}{es} = \frac{LS}{LE'} = \frac{\text{Incidence of seller}}{\text{Incidence of buyer}}$$

As you can see in figure 5 demand curve is relatively steeper and is relatively inelastic. If government imposes tax on producer, the supply curve will shift to left from S to S1. The burden of a tax shared by buyer is E'B and burden shared by seller is BC. The burden shared by buyer is greater than burden shared by seller. As E'B is greater than BC. Therefore, with relatively inelastic demand curve buyer bears most of the burden of tax.

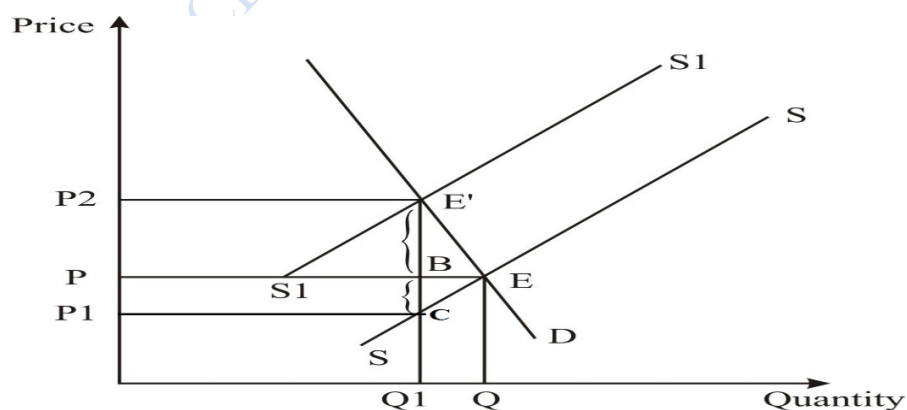


Figure 5: Incidence of taxation with relatively inelastic demand curve.



In figure 6 demand curve is elastic. If government imposes tax on producer supply curve shifts to the left from S to S1. The burden shared by buyer is E'C and burden shared by seller is CD. Goods having elastic demand curve are non- necessary or sometimes luxury goods with elastic demand therefore the burden of tax falls on the seller and as can be seen from the figure 6, CD is greater than E'C. If the demand of good will be elastic, then seller bears most of the burden of the tax.

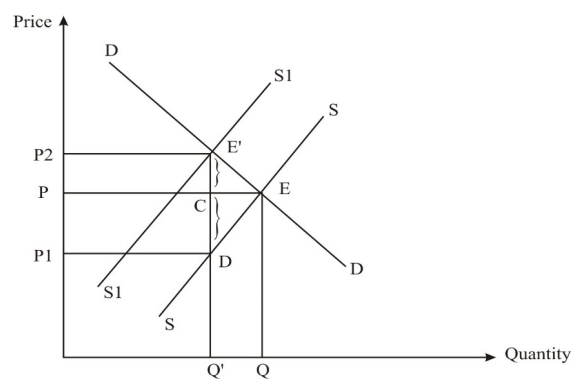


Figure 6: Incidence of taxation with relatively elastic demand curve.

Figure 7 represents perfectly inelastic demand curve. If government imposes tax on seller. The supply curve shifts to left from S to S1. Generally necessary goods represent perfectly inelastic demand curve, therefore Incidence of tax falls on buyer of commodity. So, E'E is the incidence of tax borne by buyer. If the demand is inelastic the buyer bears most of the burden of tax as it is not easy to reduce the demand at higher prices.

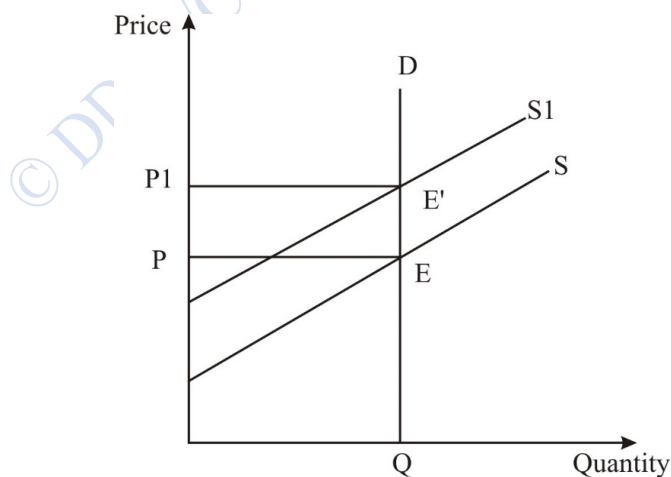


Figure 7: Incidence of tax in case of perfectly inelastic demand, so, incidence falls on buyer.



Figure 8 represents perfectly elastic demand of commodity. If the tax is imposed on seller, then supply curve will shift to left from S to S1 and incidence of taxation i.e. E'E'' will fall on the producer of commodity.

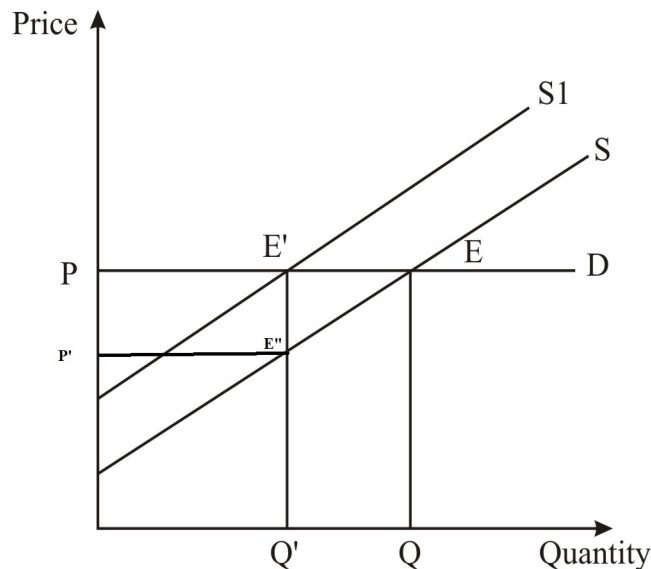


Figure 8: Incidence of tax in case of perfectly elastic demand, so, the burden falls on seller.

IN-TEXT QUESTIONS

6. A tax imposed on consumer with inelastic demand, will generate a tax burden falling more heavily on _____.
7. Tax Burden falls more heavily on the buyer when demand is _____ and supply is _____.
8. The government can place the burden of the tax on seller by collecting tax from sellers rather than buyer. (True/False)
9. A tax collected from seller has an equivalent impact to a same size of tax collected from buyer. (True/False).
10. Medicine is a necessary good, So the more burden of tax on medicine will fall on a buyer. (True/False)



8.5 LAFFER CURVE

According to Arthur Laffer, Government should impose optimal tax rate to maximize the tax revenue. According to the figure if the tax rate increases after T^* level then the tax revenue will decrease. If tax rate is less than T^* then also the tax revenue is less than the maximum amount of revenue or in other words, there is potential for increasing the tax revenue. Therefore T^* is the optimal level of Taxation.

High level of tax rate discourages workers to work more and cutting taxes may increase the revenue of the government. This theory was criticized by many as it is difficult to empirically decide the optimal tax rate in the economy. This theory does not guarantee that the reduction in tax rate will increase the collection of tax revenue.

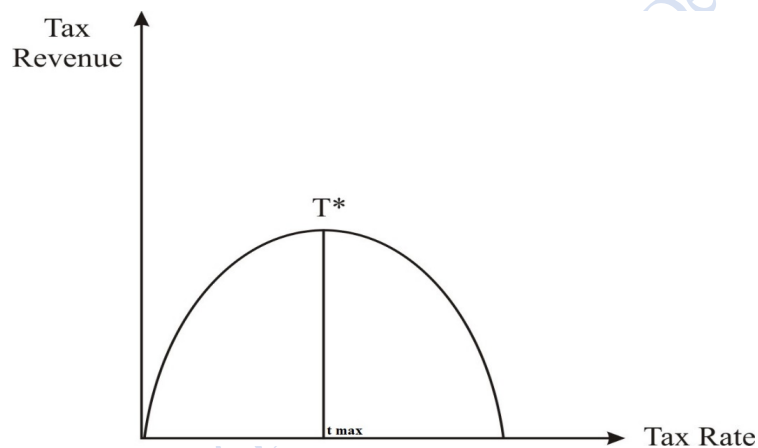


Figure 9: Laffer curve

8.6 SUMMARY

Taxes hold importance from the ancient era and are used for governance and welfare. Taxes are levied to discourage Production and consumption of certain goods and services if so desired.

Taxes create dead weight loss, causes loss of consumption, production and loss of output. One of the important aspects is whether the tax is imposed on producer or on consumer, the burden of taxation is borne by both buyer and seller. Elasticity is the important factor which decides the distribution of tax between the buyer and sellers. If demand is relatively inelastic, then buyer bears most of the burden of a tax. When supply curve is relatively inelastic then seller bears most of the burden of taxation.



Laffer curve advocates the imposition of optimal tax rate to maximize the tax revenue of the government. Any fluctuation from the optimal rate will reduce the revenue collection of the government.

8.7 ANSWERS TO INTEXT QUESTIONS

1. Both buyers and sellers
2. demand
3. decreases
4. Increases
5. Decreases
6. Buyer
7. Inelastic; elastic
8. False
9. True
10. True

8.8 SELF ASSESSMENT QUESTIONS

1. Suppose government imposes tax on luxury cars. Who are likely to bear the greater burden of the tax? Why?
2. How imposition of a tax creates Market Inefficiencies? Explain.
3. Use the following Supply and demand schedule for bikes to answer the question below.

Price	Quantity demanded	Quantity Supplied
₹300	70	30
₹400	65	35
₹500	60	40
₹600	55	45
₹700	50	50
₹800	45	55



₹900	40	60
₹1000	35	65
₹1100	30	70

Plot the supply and demand curve for Motorbikes on the graph paper. If government imposes a tax of ₹200 per Motor bike.

1. After the tax what price will be received by seller of the bike?
2. What price will be paid by the buyer?
3. Calculate the deadweight loss.
4. Calculate the quantity sold after the imposition of tax.
5. Calculate the quantity sold after the imposition of tax.
6. Calculate the difference in quantity before tax and quantity sold after tax.

8.9 REFERENCES

- Mankiw, N.G.(2018), *Principals of Microeconomics* 8th Edition.
- Frank, R. H, &Cartwright,E. (2010), *Microeconomics and behavior*, New York McGraw-Hill.
- Acemoglu, D., Laibson, D., &Lisl.J. (2017), *Microeconomics*. Pearson.



LESSON 9

PUBLIC GOOD

STRUCTURE

- 9.1 Learning Objectives
- 9.2 Introduction
- 9.3 What are Public Goods
- 9.4 Public Good and The Free Rider Problem
- 9.5 Cost and Benefit Analysis
- 9.6 Common Resources and Tragedy of Commons
- 9.7 Summary
- 9.8 Glossary
- 9.9 Answers to In-Text Questions
- 9.10 Self-Assessment Questions
- 9.11 References
- 9.12 Suggested Readings

9.1 LEARNING OBJECTIVES

After Reading this lesson students will be able to understand :

1. What are public goods?
2. Characteristic of public good
3. Pure public goods versus private goods
4. Common resources and club goods
5. Free rider problem and tragedy of commons

9.2 INTRODUCTION

You go out of your home and see some people are trying to create nuisance on street, so you called police to take control of situation. Police came and controlled the situation. In this case role of police to keep law and order is public good because your call to police will have not only benefit you but it will create positive benefit to all people living in your area. In this situation Law and Order is a public good. Public goods are consumed in groups as compared to private good which are used by individuals.



9.3 What are Public Goods

Public goods must satisfy two properties: -

(i) Not excludable

Example: - National defence,

publicstreetlights

(ii) Non- rival

Example: - public parks, Law and order

Non-excludable: it is a property of a good where it is extremely hard to exclude other person from its consumption.

Non-rival: - consumption of a good does not reduce quantity for consumption of good for another person

On the contrary, when a good having property of excludability and rivalry then it is called *private good*. Example: - Ice Cream, when one person consumes that ice cream it reduces quantity that is available to other persons so ice cream is rival in consumption and by making any payment, we can make consumption excludable.

There is other type of resources which are rival in consumption, but it is extremely hard to exclude they are called *common resources*. Example: - village water pond that has fishes which is rival in consumption, but it is extremely hard to exclude any village person to excess pond for fishing.

It should also be kept in mind that sometimes it is possible to exclude someone from consuming any good but cost to exclude that is extremely high. Example: -Restricting Persons from accessing common grazing ground in village.

Some goods are non-rival in consumption, but they hold the property of excludability which are called as *club goods*.

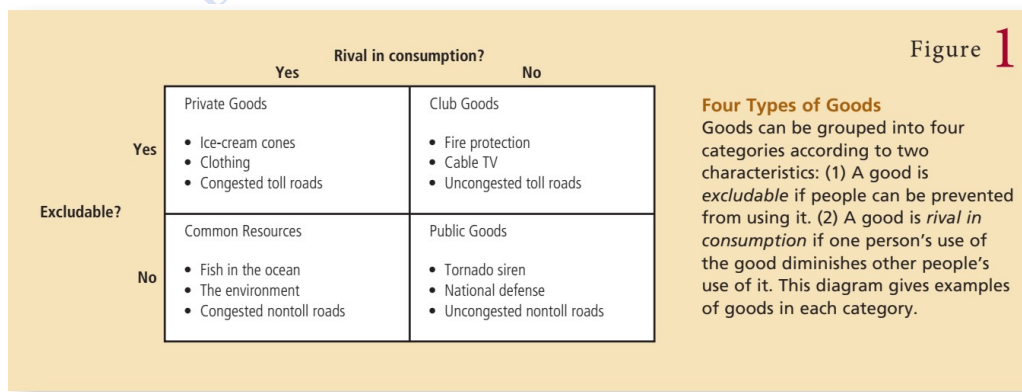




Figure 1 summaries all the different type of goods with their properties.

Even though we have used different criteria to name different goods, but their separations are not sacrosanct. Public road, which can be considered as public good until it is not congested and without tolls but when there is congestion on road it become rival and having toll will make road as excludable.

IN-TEXT QUESTIONS

1. What is the difference between pure public good and club good?
2. Can you identify goods which are excludable but not rival in consumption?
3. Can you identify goods which are rival in consumption but not excludable?
4. What are the main differences between club goods and common resources?

9.4 PUBLIC GOOD AND THE FREE RIDER PROBLEM

Free rider is a person who enjoy benefit from good but avoid any payment for the use of the good. Example: - when we want to have a security guard for our society which will benefit every person in society but there are very less persons who are willing to pay for the security service. This situation is called as free rider problem in economics. If we take a numerical example: - Let total cost for security is service is ₹ 1000 and there are 120 houses in society and each benefit ₹ 10 from security service. So total benefit to society will be ₹ 1200 from security service but everyone will try to skip payment in hope that other individual will pay which will create the problem of free rider so security service will not be provided.

The problem of free rider is arisen due to positive externality, if society develop mechanism in which each person is mandatory to pay ₹ 10 then the problem of free rider will be solved.

Positive Externality: - when action of an agent creates positive benefit to another agent without any payment form benefiting agent.

Classical example of public good: -

- (i) **National defence:**- countries spend huge amount to protect its borders and create influence in world geo-political spare. Even though there is vast debate regarding huge amount of money spend on defence given other more productive use of money in developing countries, but everyone agree that government should spend money to create common defence from enemies' aggression due to public good nature of defence.



- (i) **Basic research:** - there are two type of knowledge one is specific which is patentable like vaccine and new battery type which last longer than our traditional battery and second type is basic research like mission send to mars for detection of water by Indian space and research organisation (ISRO) or by national aeronautics and space administration (NASA), which produce basis knowledge which can be utilised by other organisations for further research.

Case study: Is lighthouse is public good or private good?

There are many goods which can be provided as public good or can be provided through market mechanism. One of the most discussed cases is lighthouse which was extremely useful in earlier time to warn about any hazard under the water. It was the duty of state to provide lighthouse, so lighthouse was a public good in earlier time. Once lighthouse was installed anyone pass near lighthouse gets benefited and if government try to collect any fee for lighthouse, then it is extremely hard to collect any fee because the use of lighthouse is non rival and non-excludable in consumption. Due to market innovations now, lighthouse is getting provided through market mechanism where private firm install lighthouse and collect money from port so if any port denies the payment, then firm can turnoff light for passing ships. So, when deciding any good as private and public good we need to consider every economic alternative to exclude the non-paying agent. There is possibility that some goods can be public and private good at same time. Another example can be public road, they are public goods until their in no congestion and no toll on road but after introduction of toll public roads become private good with properties of rival and excludable in nature.

IN-TEXT QUESTIONS

5. Can you find any freerider problem in your locality and provide solution for the problem.?
6. what is the main reason for free rider problem.?

9.5 COST AND BENEFIT ANALYSIS

In our above analysis we define what is public good and due to non-rival and non-excludable in nature we concluded that public goods should be provided by government. If we leave



the supply of public good on market, then public good will be provided in inefficient quantity. Above analysis help in determining government should provide the public good. To determine which goods should be provided and which not, the government considers the cost and benefit analysis which help to determine provision of public good. Example: - construction of a water tanker in remote area. Cost and benefit analysis is extremely useful tool to determine worthiness of any good. It is not just helpful in provision of public good, but we use to take many decisions in our real life. Example: - when we decide about going for a movie we think of total cost (like transportation, movie ticket etc.) to see a movie and total happiness we will get from watching any movie. If our benefits from seeing movie exceed benefits in terms of total cost, we will choose to go for movie.

Case study: cost and benefit analysis in determining construction of a dam

suppose government want to construct a dam which will provide drinking water to people in area, irrigation to nearby farmland and it will also generate electricity which can be used to betterment of the people in area. Let us assume that the total cost of constructing dam is ₹100 crore which will create drinking water benefit of ₹30 crore (we can think of alternative way to supply water which cost us around ₹30 crore) and irrigation benefit of ₹20 crore. Through dam we can also produce electricity worth of ₹40 crore. So, using cost and benefit analysis we can see total benefit from construction of dam is just ₹90 crore and total cost is ₹100 crore so government will try to avoid construction of dam since cost is greater than benefit if good is provided as public good. So public good will not be provided. Now suppose due to technological advancement cost of construction of the dam is reduced to ₹85 crore from ₹100 crore and other benefits remain same. Now if government apply cost and benefit analysis then it can be clearly seen that total benefit from dam is much higher than cost of construction, so it is beneficial for society to construct the dam.

The analysis of cost and benefit is a handy rule to evaluate any project, but it has one big drawback when the benefit and cost are not in same unit then we cannot use cost and benefit analysis. Example: - when cost of a person's life is compared with safety cost to protect a life.

IN-TEXT QUESTIONS

7. Since people do not reveal their total benefit that they get from public good because it may be used for tax purpose. So, can you suggest any other way to calculate total benefit from any public good.?



9.6 COMMON RESOURCES AND TRAGEDY OF COMMONS

Common resources which are rival in consumption, but they are not excludable. The property of non-excludability creates problem of over consumption of common resources. Example: - common grazing ground in village and pond which has fishes.

Tragedy of commons: - Due to non-excludability property of common resources, common resources will be exploited more than efficient level.

“Tragedy of commons” problem is arisen because of negative externality, when one member takes decision, they do not consider negative effect of their action. Example: - suppose there is a common pond in village which has fishes for villagers. Each villager takes fishing activity to maximise their catches according to her own need, but when individual take fishing activity she reduces total fishes available to other villagers. This simple “*individual maximization*” exercise will create negative affect on other individuals which is the case of negative externality. If there is any social planner, then she can distribute total fishes in some equitable manner which is allows every individual to enjoy fruit of common resource.

Case study: Tragedy of common and climate change

Climate change and global warming is the biggest problem that world is facing today. Climate change is defined as long term change in climate conditions. Example: - there used to rain in India from months of June to September but due to change in climate the duration of rainy session decreased from almost four months to two and half months. But the change in climate pattern is creating problems for whole country it adversely affects farmers due to uncertainty in cropping pattern. On the other hand, global warming is defined as along-term increase in global temperature. Main cause of global warming is excessive release of carbon dioxide when we burn fossil fuel. Since atmosphere is common good so countries use to optimise its own best quantity of fossil fuel they should burn. If every country adopts this attitude which then overall carbon release will be much higher than the maximum that environment can digest. Each country expects that other country should reduce their fossil fuel consumption then it will create the problem of “tragedy of commons.” This can be clearly observed by the negotiation between developed and developing countries on different international platform. Countries are expecting other countries to reduce their fossil fuel consumption in hope it will improve overall environment. The problem of tragedy of commons is arising due to common resource nature of environment. If the responsibility can assign, then the problem will be solved.



Solution to tragedy of commons: - property rights

The problem of tragedy of common can be solved through clearly defining property rights. Property rights provide authority to an individual to exclude another person from consuming that good. Example, when you buy an ice cream you buy right to consume that ice cream and right to exclude other person from its consumption. So, if property rights are defined then the problem of commons can be solved. In our pond example if we allotted all resource of pond to any person then market will develop a mechanism which will provide genuine cost of fishing equal to benefit an individual drives. Market will provide us an efficient solution if property rights are defined clearly.

IN-TEXT QUESTIONS

8. Can you think of any mechanism which can be applied to solve problem of commons.?
9. How can we solve the problem of tragedy of commons.?

9.7 SUMMARY

Good can be differentiated based on their properties of excludability and rivalry. If a good satisfy both properties, non-rivalry, and non-excludability then we call this good as *pure public* good. When some goods satisfy one property only then we call them common resources and club goods. Some goods do not satisfy both properties they are called private goods. The problem of commons arises due to non-excludability property of good which can be solved through defining property rights of goods. So, Property rights play very important role in dealing public goods especially common resources.

9.8 GLOSSARY

Public Good: - Goods having property of non-rival and non-excludability

Club goods: - which has at least excludability property

Common goods: - where property rights are not clearly defined

9.9 ANSWERS TO IN-TEXT QUESTIONS

1. Non-Rivalry and Non- Excludability Properties
2. Think goods like public parks
3. Common Resources
4. The Properties of Non-Rivalry and Non- Excludability



5. Think of a good which is consumed by whole society without excludability properties
6. What about property rights
7. Proxy form some private consumption good, think like this way
8. Mechanisms like auctioning the common resource and then allowing person to charge for its services
9. Again, role of property rights

9.10 SELF- ASSESSMENT QUESTIONS

- Q (1) Identify goods which are non-pure public goods and explain in each case why some excludability and diminishability are possible.
- Q (2) Why are health and education not considered as pure public goods?
- Q (3) Wireless, high-speed Internet is provided for free in the airport of a city. At first, only a few people use the service.
- (a) What type of a good is this and why?
 - (b) Eventually, as more people find out about the service and start using it, the speed of the connection begins to fall. Now what type of a good is the wireless Internet service?
 - (c) What problem might result and why? What is one possible way to correct this problem?

9.11 REFERENCES

- Mankiw, N. G. (2016). *Principles of Microeconomics*. United States: Cengage Learning.
- Laibson, D., List, J. A., Acemoglu, D. (2018). *Microeconomics: Global Edition*. United Kingdom: Pearson.

9.12 SUGGESTED READINGS

- Batina, R. G., Ithori, T. (2006). *Public Goods: Theories and Evidence*. Germany: Springer Berlin Heidelberg.
- Laudal, T. (2019). *A New Approach to the Economics of Public Goods*. United Kingdom: Taylor & Francis.



LESSON 10

POVERTY AND INEQUALITY

STRUCTURE

- 10.1 Learning Objectives
- 10.2 Introduction
- 10.3 The Notion of Poverty
- 10.4 How is Poverty Measurement
 - 10.4.1 History of Poverty Estimation in India
 - 10.4.2 Indicators of Poverty
- 10.5 Dimensions of Poverty in India
 - 10.5.1 Incidence of Poverty-All India Level
 - 10.5.2 Poverty by Social Groups in India
 - 10.5.3 Inter-State Variation in Incidence of Poverty
- 10.6 Causes of Poverty in India
- 10.7 Various Poverty Alleviation Programmes
- 10.8 Meaning of Inequality
- 10.9 Causes of Inequality
- 10.10 Measures of Income Inequality
- 10.11 Inequality in India: Patterns and Trends
 - 10.11.1 Consumption Inequality
 - 10.11.2 Income Inequality
 - 10.11.3 Regional Variation
- 10.12 Summary
- 10.13 Glossary
- 10.14 Answer to In-text Questions
- 10.15 Self-Assessment Questions
- 10.16 References
- 10.17 Suggested Readings



10.1 LEARNING OBJECTIVES

After studying this lesson, students will be able to:

1. Define the notion of the poverty.
2. Understand the various attributes of poverty.
3. Understand the various dimensions linked to the concept of poverty.
4. Critically appraise how poverty is assessed.
5. Appreciate and be able to evaluate existing programs to combat poverty.
6. Elucidate the meaning of Inequality and its type.
7. Explain the various metrics used for analyzing inequality.
8. Analyze the level of inequality in India and across the states.
9. Explain the policy implications of poverty and inequality in the economy.

10.2 INTRODUCTION

Poverty & Inequality trends in India have been the subject of intense controversy. Poverty and inequality are different concepts, but they are closely related. Given the average income, a higher level of inequality will tend to be associated with a higher level of poverty. In addition, the so-called "poverty line" can sometimes be drawn in the light of the socially accepted "minimum" standard of living, and the latter can be influenced by the level of average income, so that the measures of poverty, thus defined, can also make up for an aspect of relative inequality. In India, the problems of poverty and inequality have always been major barriers to economic development. Although India has managed to achieve the Millennium Development Goal of a 50 per cent reduction in its poverty rate, according to 2011-2012 estimates, nearly 22 per cent of India's population still lives below of the poverty line. This calls for an exploration of issues related to poverty and inequality at the national and state level.

This chapter deals with two most tough challenges faced by independent India – Poverty & Inequality. This chapter not only tries to simply understand the human reality of what it means to be poor but briefly discusses how poverty is seen in social sciences. This unit attempts to first define the poverty, understand the methods for estimation of poverty and tries to analyse the scenario of poverty in India and across the states. The causes of poverty as well as anti-poverty measures taken by government are also mentioned. Since Poverty and Inequality are inter-relates issues, one cannot be appreciated without knowing the dimension



of other the chapter also discusses with the concept of inequality, its causes, measures and trends and patterns at national and state level, which will help in building a theoretical perspective.



Source: Google Images.

The pictures of poverty and children in need given above illustrate how actually poverty look likes.

Figure 1 portrays that homelessness that keeps the certain fraction of the population from accumulating wealth and rising above the poverty line.

Figure 2 reveals that the poor children collecting garbage for sale to feed a family, afford a house, pay for education and sustain a living.

Figure 3 gives an overview of the old slum areas modern building in the background illustrating Rural-Urban disparity.

Figure 4 illustrates the occurrence of societal imbalances between the poor and rich people.

10.3 THE NOTION OF POVERTY

Poverty is a complex phenomenon with many facets, which have been varying from place to place, from time to time. According to the World Bank, poverty results from “a lack of access to assets, insufficient or inappropriate economic growth, and poor governance. “The World Bank and the UNDP remain the two leading institutions in the fight against poverty.



The UNDP (United Nations Development Programme) specifically defines three notions:

- i. **Extreme Poverty or Absolute Poverty:** A person lives in a condition of extreme poverty if they do not have the necessary income to meet their essential food needs defined on the basis of minimum caloric needs (1800 calories per day and per person (WHO).
- ii. **General Poverty or Relative poverty:** A person lives in a condition of general poverty if he does not have sufficient income to meet his essential non-food needs clothing, energy, housing, as well as food.
- iii. **Human poverty:** It is described as the absence of basic human capabilities such as illiteracy, malnutrition, reduced longevity, poor maternal health, preventable disease.

In social sciences poverty is commonly understood in discrete senses. There is no unique definition of poverty. It has several meanings that are connected by a number of similarities. Several Economists, demographers, scholars, and social scientists shed light on various ways to measure and elucidate the concept of Poverty.

- ❖ Baratz and Grigsby refer to “Poverty as a severe lack of physical and mental well-being, closely associated with inadequate economic resources and consumption”.
- ❖ Amartya Sen, the famous Indian economist who was awarded the Nobel Prize in Economics Services in the year 1988, defined “Poverty as a failure to achieve certain minimum capabilities”.
- ❖ Wresinski, defines “Poverty as lack of security in terms of a lack of rights”.
- ❖ Abhijit Banerjee, the Indian American economist writes: Poverty is not one problem and it's like a cancer that manifests different problems and each one deserves its own answer...there are different reasons why people are depressed, people are sick, people have no access to financial markets, people have no access to infrastructure.

10.4 HOW IS POVERTY MEASURED?

India has a long history of poverty measurement studies. The erstwhile planning commission now called as NITI Aayog (National Institution for Transforming India) was the nodal agency in India for poverty assessment. Based on the methodology suggested by expert groups/committees set up by the Planning Commission from time to time, India has undertaken periodic poverty incidence assessments since the 1960s. In pre-independent India, the poverty rate in India was measured from an exogenously determined poverty line quantified in terms of consumption expenditure per capita over a month and the distribution of classes of people obtained from the National Sample Survey Office (NSSO). Households



whose consumption expenditure is below the poverty line are said to be “below the poverty line (BPL)” and considered poor. Consumption is metered in terms of a set of goods and services called the reference poverty line baskets (PLB).

Thus, India's poverty estimate was based on two essential elements:

- ❖ Information on consumption expenditure and its distribution among households is provided by NSS Consumer Expenditure Surveys.
- ❖ These household expenditures are assessed by reference to a given poverty line.

10.4.1 History of Poverty Estimation in India

The below chart illustrates the various committees constituted for the measurement of poverty estimation in India. Most importantly the “Grand Old Man of India” and “Unofficial Ambassador of India”- Dadabhai Naoroji was the first to discuss the concept of Poverty Line in India. Subsequently, several attempts were made through a number of committees to identify the number of poor in the country.

Chart 1: Poverty Estimation in India

Pre Independence Poverty Estimation	Post-Independence Poverty Estimation
<ul style="list-style-type: none">• The Bombay Plan (1944): (Rs. 75 per capita per year)• National Planning Committee (1938) : (Rs. 15 to Rs. 20 per capita per month)• Poverty and unbritish rule in India (1901) : (Rs.16 to Rs.35 per capita per year)	<ul style="list-style-type: none">• Rangrajan Committee (2012): (Rs.972 and Rs.1407 per capita per month in rural and urban areas respectively.)• Tendulakar Expert Group (2009): (Rs.816 Rs.1000 per capita per month in rural and urban areas respectively)• Lakdawala Expert group (1993)• Y K Alagh Committe (1979): (2400 and 2100 calaries per capita per day; Rs.49.09 and Rs. 56.64 per capita per month at 1973-74 prices in rural and urban areas respectively.• VM Dandekar and N Rath (1971) : (2250 calaries percapita per day; Rs. 15 and Rs.22.5 per capita per month in rural and urban areas respectively at 1960-61 prices)• Working Group (1962): (Rs. 20 to Rs. 25 per capita per year in rural and urban areas respectively at 1960-61 prices)



IN-TEXT QUESTIONS

1. If person don't have sufficient income to meet his/her non-food needs such as clothing, housing etc. is referred to as
 - (i) Relative Poverty
 - (ii) Absolute Poverty
 - (iii) Chronic Poverty
 - (iv) Transient Poverty
2. According to Y L Alagh Committee (1979), Poverty Line for the person is fixed at Rs.per capita per month for rural areas and Rs..... for urban areas.
3. Two Leading Institutions for fighting against Poverty are &.....
4. DadabhaiNaoraji was the first to discuss the concept of Poverty Line. True/False
5. NITI Aayog Stands for

10.4.2 Measures of Poverty

Income Indicators of Poverty

1. **Head Count Index:** The head count ratio measures the proportion of population below the poverty line. It is used for comparing the poverty situation in two zones or two regions. It is expressed as percentage and mathematically defined as follows:

$$\text{Head Count Ratio (HCR)} = \frac{\text{Total number of people below the poverty}}{\text{Total Population}} * 100$$

Total Population

Advantage:The main advantage of this index is that it easy to understand and compute and is the most widely used measure to estimate poverty. But it does not indicate the degree of poverty and the distribution of income among the poor.

2. **The Poverty Gap Index (PGI):** The poverty gap index is a measure of the intensity of poverty. It measures the average poverty gap in the population as a proportion of the poverty line. In other words, it tells how poor the poor are. The poverty gap index is an improvement over the head count index because it estimates the depth of poverty by considering how far, on the average, the poor are from the poverty line.

Mathematically it can be expressed as,

$$PGI = \frac{1}{N} * \sum_{c < z} \left[\frac{z - c}{z} \right]$$

Where,

N = Total Population

q = Number of Poor

z = Poverty line cut off



c = consumption expenditure of the poor

Advantage:The main advantage of this index is that it helps provide an overall assessment of a region's progress in poverty reduction and the evaluation of specific public policies or private initiatives.

3. **Squared Poverty Gap Index (SPGI):** The squared poverty gap index is also known as poverty severity index. It is computed by averaging the square of poverty gap ratio for each individual, and thus attributes more weight on the observations that falls short of the poverty line.

Mathematically it can be expressed as,

$$SPGI = \frac{1}{N} * \sum_{c < z} \left[\frac{z-c}{z} \right]^2$$

Where,

N = Total Population

q = Number of Poor

z = Poverty line cut off

c = consumption expenditure of the poor

Advantage: The squared poverty gap index is more beneficial to the poor who are further away from the poverty because they will not receive the same amount of government assistance.

4. **Sen-Shorrocks-Thon Index:** The Sen-Shorrocks poverty index is a composite poverty measure which combines the the proportion of poor people, the depth of their poverty, and the distribution of welfare among the poor.

Mathematically, this index is expressed as:

$$P_{sen} = H * G_z + PGI * (1 - G_z)$$

Where,

H= Head Count Ratio

PGI = Poverty Gap Index

G_z = The Gini coefficient of poverty gap ratios for the population

Non-Income Indicators of Poverty



1. Human Development Index

The Human Development Index (HDI) is a statistical tool used to measure a country's overall achievements in its social and economic dimensions. The social and economic dimensions of a country are based on people's health, their level of education and their standard of living.

Renowned Pakistani economist Mahbub ulHaq developed the Human Development Index in the year 1990, which was later used to measure the country's development by the United Nations Development Program (UNDP). The computation of the index combines four major indicators:

- i. Life expectancy for health,
- ii. Expected years of schooling,
- iii. Average years of schooling for education and
- iv. Gross national income per capita for standard of living.

Each year, the UNDP ranks countries based on the HDI ratio published in its annual report. The HDI is one of the best tools to track the level of development of a country, as it combines all the main social and economic indicators responsible for economic development.

2. Human Poverty Index

The human Poverty Index was introduced in the year 1997 by the United Nation with the aim of bringing together a composite index of the different characteristics of deprivation of quality of life to arrive at an aggregate judgment on the extent of poverty in a community. The Human Poverty Index (HPI) measures deprivation in basic human development by combining the basic dimensions of poverty and reveals the differences between human poverty and income poverty.

The Human Poverty Index focuses on the deprivation of the three essential elements of human life already reflected in the Human Development Index: (i) Longevity; (ii) knowledge; and (iii) a decent standard of living. The HPI is derived separately for developing countries (HPI-1) and a group of selected high-income OECD countries (HPI-2) to better reflect socio-economic differences as well as the very different measures of deprivation in both groups.

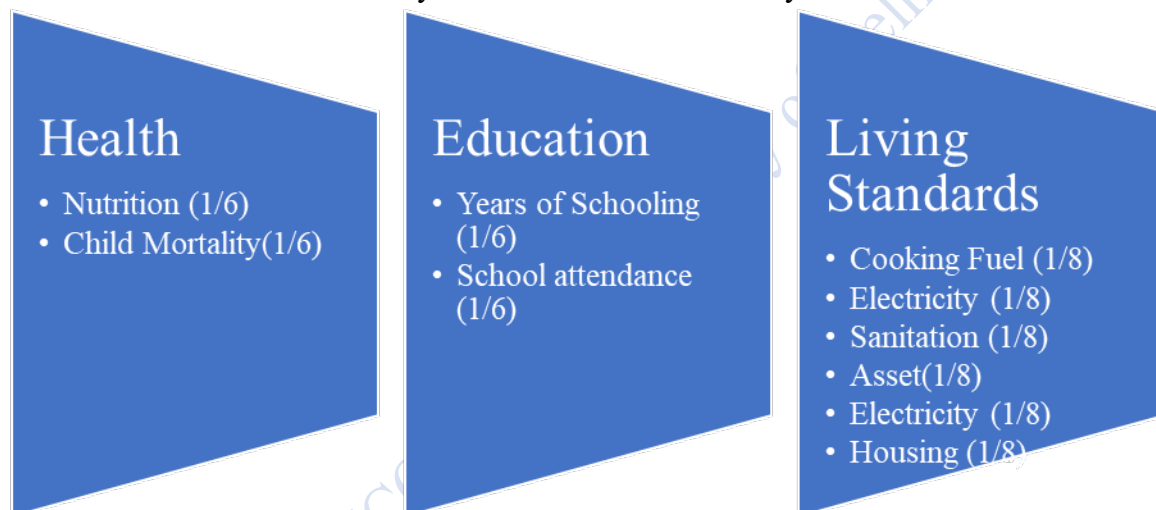
3. Multi-Dimensional Poverty Index (MPI)

Multidimensional poverty index was launched by the United Nation Development Programme (UNDP) and the Oxford Poverty & Human Development Initiative (OPHI) in the year aimed at measuring the non-income dimensions of poverty, in order to provide a



more comprehensive assessment of the extent of poverty and deprivation. The Multidimensional Poverty Index tracks deprivation across three dimensions and 10 sub-indicators (Refer to Chart 2). The Multi-Dimensional Index first identifies which of these 10 deprivations each household experiences, and then identifies households as poor if they suffer deprivations across one-third or more of the weighted indicators. Based on Alkire Foster's methodology, the MPI is created by multiplying two numbers: (i) the percentage of the population that is poor and (ii) the average percentage of weighted indicators experienced by the poor (intensity).

Chart Multidimensional Poverty Index: Indicators of Poverty



Most importantly, the MPI illustrates who is poor and how poor they are and can be used to create a comprehensive picture of people living in poverty. It allows comparisons both between countries and regions of the world, and within countries by ethnic group, urban/rural area, sub-national region and age group, as well as other key household and community characteristics.

Apart from the above-mentioned indexes, there are few more measures to assess the poverty such as watt index, but those discussed above are the widely used among the scholar, stakeholders and learners etc.

NUMERICAL EXAMPLE

Lets us take a numerical example to understand the measures of poverty.



Example 1 Monthly Food Expenditure of Eight Households in Delhi and Gujarat.

Table 1 gives the data on the monthly food expenditure of eight households in Gujarat and Delhi.

State	Monthly Per Capita Expenditure (in Rupees)						
	(1)	(2)	(3)	(4)	(5)	(6)	(7)
Delhi	859	1000	900	875	650	675	790
Gujarat	1150	1050	1300	1000	450	500	490

From the data given in Table 1, our objective is to compute the Head Count Ratio (HCR), Poverty Gap Ratio and Squared Poverty Gap Ratio for both the states separately.

For the moment, just concentrate on the first seven columns of the table 1, which relate to the monthly food expenditure and poverty line monthly food expenditure cut off which is given to us as Rs.700.

Head Count Ratio

The head Count Ratios based on the data for the two states are as follows:

HCR_i = Number of Households below the Poverty Line

$$\frac{\text{Number of Households below the Poverty Line}}{\text{Total Population}} * 100$$

Total Population

Note: i represent individual states.

$$\begin{aligned} \text{HCR}_{\text{Delhi}} &= 2/7 \\ &= 29\% \end{aligned} \tag{1.1}$$

$$\begin{aligned} \text{HCR}_{\text{Gujarat}} &= 3/7 \\ &= 43\% \end{aligned} \tag{1.2}$$

The results show that 29 per cent and 43 per cent are below the poverty line in Delhi and Gujarat, respectively.

Let us return to the example,



Poverty Gap Ratio

The Poverty Gap ratio is calculated as,

$$PGI_i = \frac{1}{N} * \sum_{c < z} \left[\frac{z-c}{z} \right]$$

Where,

N = Total Population

q = Number of Poor

z = Poverty line cut off

c = Monthly food expenditure of the poor

From the data given in the table, we can compute the ratio:

$$\begin{aligned} PGI_{Delhi} &= 1/10 \left[\frac{(700-650)}{700} + \frac{(700-675)}{700} \right] \\ &= 0.0107 \end{aligned} \tag{1.3}$$

$$\begin{aligned} PGI_{Gujarat} &= 1/10 \left[\frac{(700-450)}{700} + \frac{(700-500)}{700} + \frac{(700-490)}{700} \right] \\ &= 0.0942 \end{aligned} \tag{1.4}$$

Equation (1.3) and (1.4) reflects that the depth of the poverty in the states. On average, the poor have an expenditure shortfall of 1.07 per cent and 9.43 per cent from the poverty line in Delhi and Gujarat, respectively.

Squared Poverty Gap Ratio

The next important concept is the Squared Poverty Gap Index to illustrate the severity of Poverty.

Using the data given in Table 1 and Poverty Gap Ratio of both states, we have obtained the Squared Poverty Gap Ratio results:

$$SPGI_i = \frac{1}{N} * \sum_{c < z} \left[\frac{z-c}{z} \right]^2$$

Where,

N = Total Population



q = Number of Poor

z = Poverty line cut off

c = Monthly food expenditure of the poor

$$\begin{aligned} \text{SPGI}_{\text{Delhi}} &= 1/10 \left[\frac{(700-650)^2}{700} + \frac{(700-675)^2}{700} \right] \\ &= 0.64\% \end{aligned} \quad (1.5)$$

$$\begin{aligned} \text{SPGI}_{\text{Gujarat}} &= 1/10 \left[\frac{(700-450)^2}{700} + \frac{(700-500)^2}{700} + \frac{(700-490)^2}{700} \right] \\ &= 123.7 \end{aligned} \quad (1.6)$$

How do you interpret Equation (1.3) & (1.4)? We can say that the poverty in Gujarat is more severe than the Delhi. We have already discussed the concept of Squared Poverty Gap in Section 1. The Squared Poverty Gap reflects the severity of poverty by attributing more weights to individual which falls short of the poverty line so as to reflect the inequality among the poor.

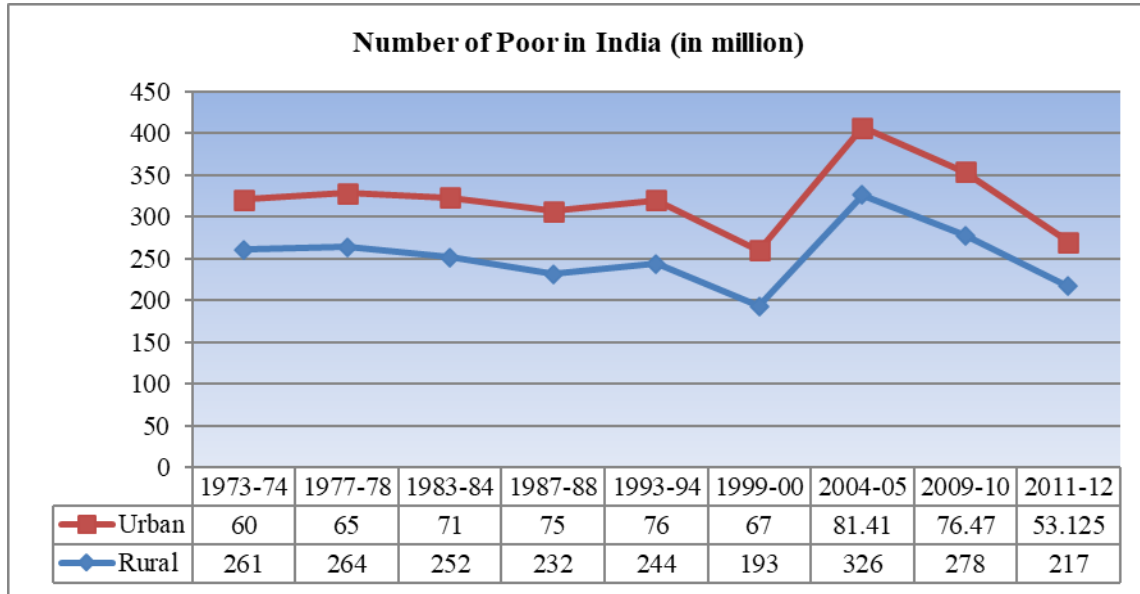
10.5 DIMENSIONS OF POVERTY IN INDIA

10.5.1 Incidence of Poverty at All-India Level

High levels of poverty are synonymous with poor quality of life, deprivation, malnutrition, illiteracy and poor human resource development. The eradication of poverty is an integral part of the strategy for economic development in India. The erstwhile planning commission (replaced by the National Institution for Transforming India) has been estimating the incidence of poverty at both the national and state level on the basis of the consumption expenditure data collected by the National Statistical office. Figure 1 and Figure 2 illustrates the number of poor and their proportion in the population for the period 1973-2012.

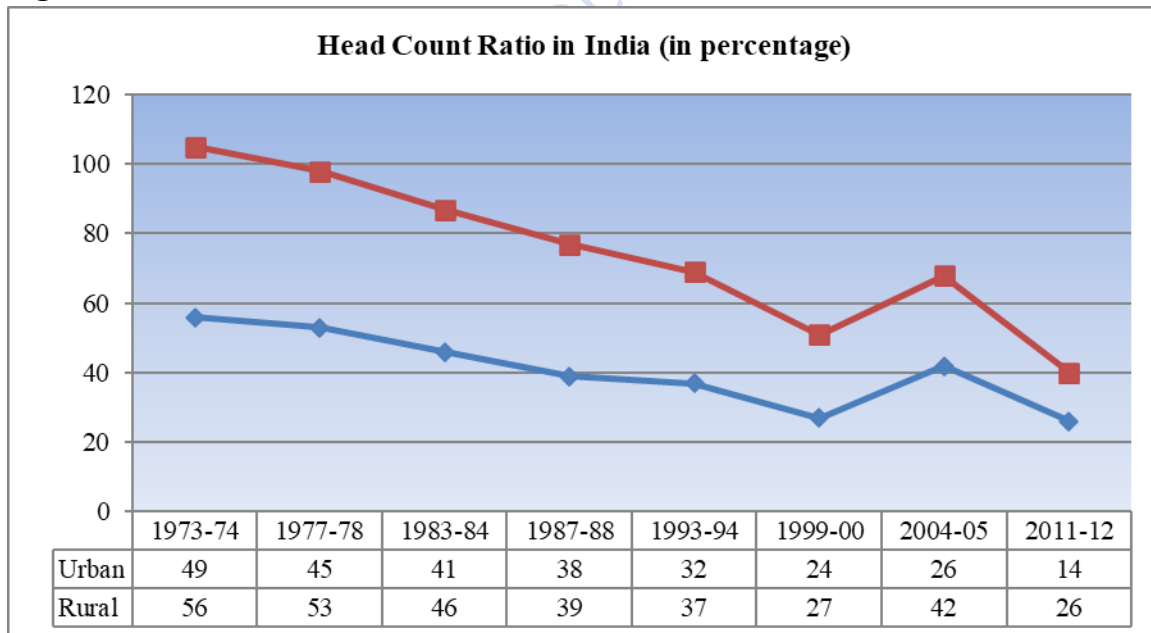


Figure 1 Number of Poor in India, 1973-2012



Source: Indian Economic Survey, Technical Report Poverty in India 1974 and Reserve Bank of India.

Figure 2 Head Count Ratio in India, 1973-2012



Source: Indian Economic Survey, Technical Report Poverty in India 1974 and Press Note on Poverty Estimates: 2011-12, Government of India (2013).



It is clear from the Figure 1 and Figure 2 that the poverty ratios have declined from 56 per cent in 1973-74 to 26 per cent in 2011-12 in rural areas and from 49 per cent to 14 per cent in urban areas. If this trend continues, the proportion of the population below the poverty line may come down to less than 10 per cent in the coming years. The absolute number of the poor had, however, declined from only 320 million in 1973-74 to about 270 million in 2011-12 due to the high population growth of the country. Although there has been progress in eliminating poverty at the macro level, but there exist large rural-urban and interstate disparities which has been discussed in the later part of the Unit.

10.5.2 Poverty by Social Groups in India

In this section we will explain the consideration of poverty rates for different social groups, which are given in the following table:

Table 2 Poverty Rates by Social groups in India, 1983-2011(%)

Location/ Social Groups	1983- 84	1993- 94	1999- 00	2004-05 (R.E)	2009- 10	2011- 12	Percentage Change
	(1)	(2)	(3)	(4)	(5)	(6)	(1,6)
Rural							
SC	58.10	48.10	36.10	52.70	43.50	31.50	-46
ST	63.80	52.20	45.90	61.90	47.10	45.30	-29
Others	37.00	31.10	21.60	26.20	21.10	22.70	-39
All	45.60	37.10	27.10	41.80	33.80	25.40	-44
Urban							
SC	56.50	49.90	38.60	40.00	33.00	21.70	-62
ST	54.20	42.20	34.80	35.00	28.80	24.10	-56
Others	39.10	30.60	20.60	15.80	11.90	15.40	-61
All	42.20	33.70	23.70	25.70	20.90	13.70	-68

Source: Chapter 10: Scheduled Castes and Scheduled Tribes, National Institute of Rural Development and Panchayati Raj



It can be observed that compared to 25% of the entire population living below the poverty line in rural areas in 2011-12, 32% of the Scheduled Caste (SC) population and 45% of the Scheduled Tribes (ST) population lived below the poverty line. There was a drop in the poverty rate of 20% for the whole population, 27% for SCs and 19% for STs compared to 1983-84. This implies that the poverty rate fell faster for SCs than for STs. A similar trend is observed in urban areas where the proportion of people living below the poverty line decreased more rapidly for SCs and STs. However, there is a significant difference between rural and urban areas. In rural areas, the proportion of the SC population living in poverty is lower than the poverty rate of the ST population. The situation is reversed in urban areas except for the financial year 2011-12. As a result, the ratio of people living in poverty for SCs and STs to (the whole) population below the poverty line has changed significantly, as shown in Table 2.

10.5.3 Inter-state Variation in Incidence of Poverty

As discussed above, the poverty ratios (expressed as a percentage of population below the poverty line by the total population) has witnessed a steady decline from 55 per cent in 1973-74 to 22 per cent in 2011-12 at all India level. But the success rate of eliminating poverty varies from state to state. Estimates show while the pan India Head Count Ratio (HCR) was 22 per cent in 2011-12 states like Manipur (36.89), Arunachal Pradesh (34.67), Bihar (33.74), Odisha (32.59), Madhya Pradesh (31.65), Assam (31.98) and Uttar Pradesh (29.43) had above all India poverty level. Arunachal Pradesh and Manipur continue to be the two poorest states with poverty ratios of 34.67 and 36.89 per cent respectively. The other states with high incidence of poverty are Karnataka, Maharashtra, Mizoram, Nagaland and West Bengal. In comparison between the financial years 1973-74 and 2011-12, there has been a significant decline in poverty in Kerala, Goa, Andhra Pradesh, Sikkim and Tamil Nadu. States like Punjab and Haryana have traditionally succeeded in reducing poverty with the help of high agricultural growth rates. Kerala has focused more on human resource development. In West Bengal, land reform measures have helped in reducing poverty. In Andhra Pradesh and Tamil Nadu public distribution of food grains could have been responsible for the improvement.

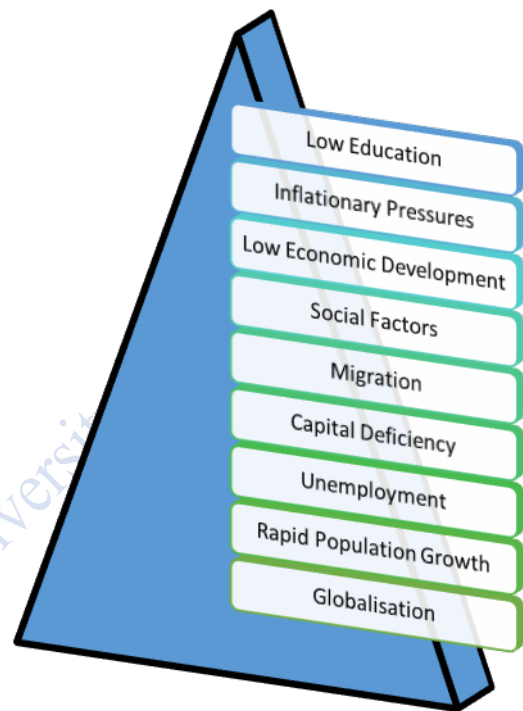
10.6 CAUSES OF POVERTY IN INDIA

1. **Rapid Population Growth:** A high rate of population growth in India, especially among the poor, is responsible for the poverty problem in the country. Population growth among the poor is high due to their illiteracy, traditional attitudes, lack of family planning practices, preference for the male child, etc. It is obvious that they are unable to provide



for even the most basic necessities of the family members due to their big family size and low income.

2. **Low Education:** Another underlining reason of poverty is the low level of education of the poor. The poor people are illiterate or semi-educated and, therefore they can only do low-paying jobs. This justification focuses on the low levels of income among the poor.
3. **Low Economic Development:** The low economic development is one of the most important factors that has led to poverty. A low rate of economic development implies a low per capita income, which implies a low standard of living. Low per capita income growth has tended to perpetuate poverty.
4. **Inflationary Pressures:** The steep and continuous rise in prices, especially of basic commodities, has added to the miseries of the poor. The sharp rise in prices has led to a decline in the real income of fixed-income and low-income earners. This has led to a decline in their purchasing power which in turn leads to a low standard of living.
5. **Unemployment:** One of the main causes of poverty is the ever-growing army of unemployed in our country. The number of job seekers is growing at a faster rate than the expansion of employment opportunities. For instance, with an unemployment rate of 4.2% in 2020 (CMIE), India is plagued by chronic unemployment and underemployment. This leads to a drop in production and, consequently, a drop in income and heavy indebtedness. The problem of unemployment in India compounds the problem of poverty.
6. **Migration:** Poverty and vulnerability are likely to have two contradictory effects on migration: by providing incentives to migrate, either as a strategy to diversify livelihoods or to escape from destitution; but also by reducing the ability to migrate because the transfer costs involved (in terms of financial, human, physical and social capital) are too high. It has been observed that due to the large migration of people from





rural to urban areas in search of employment, there has been a significant increase in urban poverty.

7. **Social Factors:** Various social factors such as education, caste system, joint family system, social custom etc. have hampered the process of economic growth and hence resulting in poverty.
8. **Capital Deficiency:** The root cause of the capital deficit in underdeveloped countries is the low level of real and per capita national income, which can lead to disinvestment, low production and poverty.
9. **Globalisation:** According to Luke Martell, Globalisation is "the incorporation of disadvantaged countries into an open global economy" (Martell 2017, 148). Many studies have strengthened both the positive and negative impact of globalization on poverty:

Positive Impact

- i. Greater employment opportunities
- ii. Free Trade
- iii. Efficient Markets
- iv. Mobilization of capital and Labour

Negative Impact

- i. Income inequalities
- ii. Increasing gap between the rich and the poor
- iii. Competition among developing countries
- iv. Decrease in per capita income
- v. Indebtedness

The relationship between the Globalisation and Poverty is quite a complex issue.

From the above discussion, we have understood that poverty is a multidimensional challenge for India which must be treated on a war footing.

10.7 VARIOUS POVERTY ALLEVIATION PROGRAMMES

Alleviation of Poverty is one of the world's important challenges. The Government of India time to time have implemented various programmes and policies to alleviate poverty in the country. Some of the flagship programmes implemented by the government to eradicate poverty are: (i) Bharat Nirman(1980); (ii) National Social Assistance Programme (1995); (iii) Employment Assurance Scheme (1993); (iv) Swarnjyanti Gram Swarozgar Yojana (1999); (v) Jawaharlal Nehru National urban Renewal Mission (2005); (vi) Integrated Rural Development Programme (1978); (vii) Pradhan Mantri Gramin Awaas Yojana (1985);(viii)



Food for Work Programme (2004); (ix) Mahatma Gandhi National Rural Employment Guarantee Act (2005); (x) National Food Security Mission (2007); (xi) Pradhan Mantri Jan Dhan Yojana (2014) and; (xii) Pradhan Mantri Suraksha Bima Yojana (2015).

IN-TEXT QUESTIONS

6. Which of the following is the poverty estimation measure?
 - i. Sen-Shorrocks-Thon Index
 - ii. Atkinson Index
 - iii. Theil index
 - iv. All of these
7. Three Dimensions of Multidimensional Poverty Index are
8. The percentage of Population below the Poverty Line in the year 2011-12 is
9. Which of the following is the major cause of Poverty in India?
 - i. High Population Growth
 - ii. Economic development
 - iii. Migration
 - iv. Deflation
10. Renowned Pakistani economist Hafeez Ahmad Pasha created the Human Development Index in the year 1990. True/False

10.8 MEANING OF INEQUALITY

Inequalities can be viewed from different angles, all of which are interrelated. The most common measure is income inequality, which refers to the extent to which income is evenly distributed across a population. Related concepts are lifetime inequality (inequality of an individual's income over their lifetime), wealth inequality (distribution of wealth between households or individuals at a given time) and inequality of opportunity (impact on income of circumstances over which individuals have no control, such as family socioeconomic status, gender or ethnicity). All of these concepts of inequality are linked and offer different but complementary perspectives on the causes and consequences of inequality, thus providing better guidance to governments when designing specific policies aimed at tackling inequality.

10.9 CAUSES OF INEQUALITY

A series of global and national factors which may reinforce each other have been proposed in the theory and empirical literature to explain the trends in income inequality. Key strengths include the following:

- ❖ Global factors, such as technological progress, globalization and commodity price cycles, play an important role. For example, technological progress has contributed to the skill premium, as people with higher education have a comparative advantage in the use of new technologies (Card and DiNardo, 2002). In Western Europe and the



United States, technological progress has also resulted in fewer middle-class jobs, a phenomenon known as job polarization (Goos and Manning, 2007).

- ❖ Country-specific factors, such as those related to economic developments and economic stability as well as national policies including financial integration, redistributive fiscal policies and the liberalization and deregulation of labor markets and products also play an important role in explaining trends in inequality within countries.

10.10 MEASURES OF INCOME INEQUALITY

There are different techniques for measuring the inequality. The most commonly used methods of measuring inequality are discussed below:

1. **Range:** In statistics, Range of a set of data is defined as the difference between the two extreme observations. In other words, range is the difference between the largest and smallest observation of the data set. Mathematically, the indicator can be expressed as,

For ordered data set = $(n_1, n_2, n_3, \dots, n_n)$

Range = $n_1 - n_2$

Where n_1 is the greatest observation in the given data set and n_2 is the smallest observation.

Let us consider a numerical,

If we have five observations in a given dataset i.e., 25, 45, 55, 65, 75, the range will be equal to $(75-25) = 50$.

Advantages and Disadvantages of Range = This is the simplest and easiest method to analyze the inequality. But the major drawback of this method is that it ignores all other observations except two and is very much affected by fluctuations of sampling and outliers.

2. **Coefficient of Variation:** The Coefficient of Variation (CV) also known as Relative Standard Deviation is the ratio of standard deviation to the mean population. The higher the value of the coefficient of variation, the greater will be the dispersion. Let us consider an example in order to understand the measure of inequality,



Example 2 Hourly Earnings in Portugal and Austria (€)

Table 5 gives the data on hourly earnings (€) of five individuals in Portugal and Austria.

	Portugal	Austria
Lucas	58	28
Oliver	60	28
Jennifer	61	22
Christopher	59	58
David	62	48
Mean	60	36.8
S.D.	1.41	13.76
C.V	2.36	37.43

Interpretation

- ❖ If we look at the hourly earnings, Portugal seems to be a better as the hourly earnings is considerably lower when compared with Austria.
- ❖ The CV of Portugal is 2.36 per cent whereas for Austria is 37.43 per cent.

Thus, the better option is to work in Portugal.

3. The Palma Ratio

The Palma Ratio is based on the work of economist José Gabriel Palma. It is the ratio of the national income shares of the richest 10 per cent households to the bottom 40 per cent.

Numerical Example

Let us take a numerical example to analyze the inequality using the Palma Ratio.

Table 6 Share of National Income

Country	Income Share (%)		Palma Ratio
	Richest 10 %	Poorest 40%	
Brazil	43.5	11.4	3.8



South Africa	51.5	8.2	6.3
Botswana	42.5	11.9	3.6
Zambia	44.4	8.9	5.0
Namibia	48.3	9.9	4.9

The higher the value of the Palma Ratio, the greater will be the inequality. In our example, the inequality is greater in country South Africa.

4. The McLoone Index

The McLoone index divides the sum of all observations below the median, by the median multiplied by the number of observations below the median.

Let us consider a data set of the income of 15 individuals in Canada,

$$Y = (15, 40, 58, 77, 88, 98, 220, 300, 310, 325, 345, 450, 555, 625, 800)$$

In our example median value is 300.

Note: If the number of observation in the data set is odd, median = $[(n+1/2)]^{\text{th}}$ and in case of even, median = $(n/2)^{\text{th}}$, where n is the number of observations.

The sum of observations below the median = $15+40+58+77+88+98+220 = 596$.

$$\begin{aligned} \text{Hence, McLoone Index} &= 596 / (300 * 7) \\ &= 596 / 2100 \\ &= 0.28 \end{aligned}$$

5. 20/20 Ratio

The 20:20 ratio, which measures income inequality, compares the average income of the richest 20% of a given society to the poorest 20% of the society.

6. Range Ratio

The Range Ratio is computed dividing a value at a predetermined percentile by the value at a lower predetermined percentile.

Let us consider the following data set to understand the Range Ratio,

$$D = (55, 58, 88, 97, 98, 120, 200, 221, 248, 250, 254, 267, 297, 324, 340)$$



If we choose the 95th and 5th percentile, then the Range Ratio will be,

$$95^{\text{th}} \text{ Percentile} = (0.95 * 15) = 14^{\text{th}} \text{ observation} = 324$$

$$5^{\text{th}} \text{ Percentile} = (0.05 * 15) = 1^{\text{st}} \text{ observation} = 55$$

$$\text{Range Ratio} = 324 / 55$$

$$= 5.89$$

Note: Any two percentiles can be used for producing the Range Ratio. But most of the contexts, this 95/5 ratio is used also known to as the Federal Range Ratio.

Disadvantage: Like the range, range ratio also considers the two observations and is very much affected by fluctuations of sampling.

7. Decile Dispersion Ratio

Decile Dispersion Ratio also referred to as Inter-Decile ratio is the simplest indices to measure the inequality. It presents the ratio of the average income of the richest x per cent of the population to the average income of the poorest x per cent.

Disadvantage: This measure is vulnerable to extreme values and outliers.

8. Atkinson Index

This is most significant social welfare-based measure of inequality developed by the economist Tony Atkinson in year 1970. The crux of the Atkinson index is related to the concept of equally distributed equivalent level of income level, which is defined as the percentage of total income that a given society would have to give up in order to have more equal shares of income between individuals in that society.

Note: The index takes the value between zero and one.

Advantage: The advantage of Atkinson index is that it provides a comprehensive ranking of income distributions and makes explicit the social welfare function that underlies the income inequality measure, which could be useful for political decisions.

9. Lorenz Curve

A Lorenz curve is a graphical representation of measuring inequalities. It was developed by the American economist Marx O. Lorenz in the year 1905 for the measurement of economic inequalities such as distribution of wealth and income between different countries or between different time periods.



Distinctive Feature of Lorenz Curve: An idiosyncratic feature of the Lorenz curve is to deal with the cumulative values of the variable and the cumulative frequencies rather than its absolute value and the given frequencies.

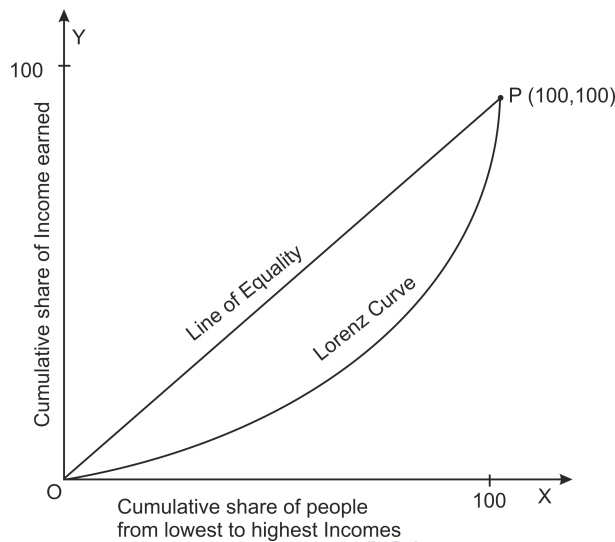


Figure 1

Construction of Lorenz curve

The technique for drawing the Lorenz curve is quite simple and consists of the following steps mentioned below:

- i. Calculate the cumulative values of size of items (in case of discrete series) or mid-points (in case of continuous series).
- ii. Calculate the percentages for these cumulative values. (Note: The last cumulative total will always be equal to 100).
- iii. Determine the cumulative frequencies and calculate the percentage for each cumulative frequency.
- iv. On both axes, we start from 0 to 100 where X-axis represents the percentage of cumulative frequencies and Y-axis represents the percentage of the cumulated values of the variable.
- v. Draw the diagonal line joining the origin O (0, 0) with the point P (100,100). This line is known as “line of equal distribution”.
- vi. The last and final step is to plot the percentages of the cumulated values of the variable against the percentages of the corresponding cumulative frequencies and join these points with free hand to obtain the lorenz curve.



Illustrative Example

Table 7 gives the information on the income of the workers in Automotive Company named as Ford Motor.

Monthly Income	Mid-Value	Cumulative Income	% C. I	No. of workers	C.F of workers	% C.F of workers
0- 100	50	50	6.25	5	5	9.09
100-200	150	200	25	10	15	27.27
200-300	250	450	56.25	15	30	54.55
300-400	350	800	100	25	55	100

Let us consider the Lorenz curve (figure) for the distribution of the income,

Hence, the farther the Lorenz curve is from the 45-degree line or line of equal distribution, the greater the inequality in distribution of income.

10. Gini Coefficient

It is the most widely cited measure of inequality. It measures the extent to which the distribution within an economy deviates from a perfectly equal distribution. The index is calculated as the ratio of the area between the two curves (Lorenz curve and 45-degree line) to the area below the 45-degree line. In the figure above, it is equal to $A/(A+B)$. A higher Gini coefficient represents a more unequal distribution. According to World Banking data, between 1981 and 2013, the Gini index varied between 0.3 and 0.6 worldwide.

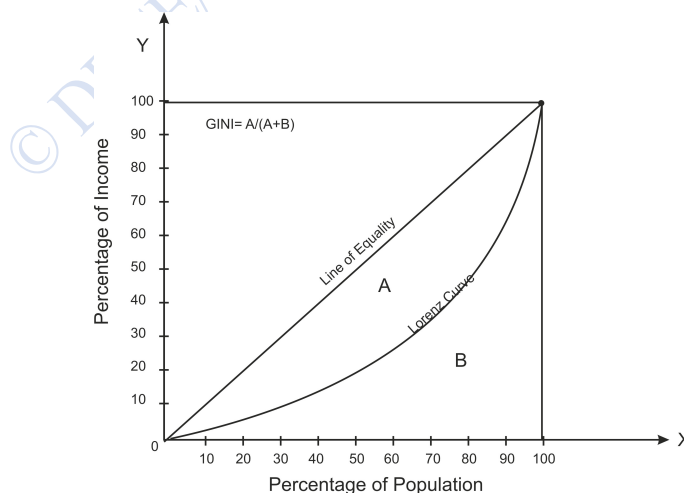
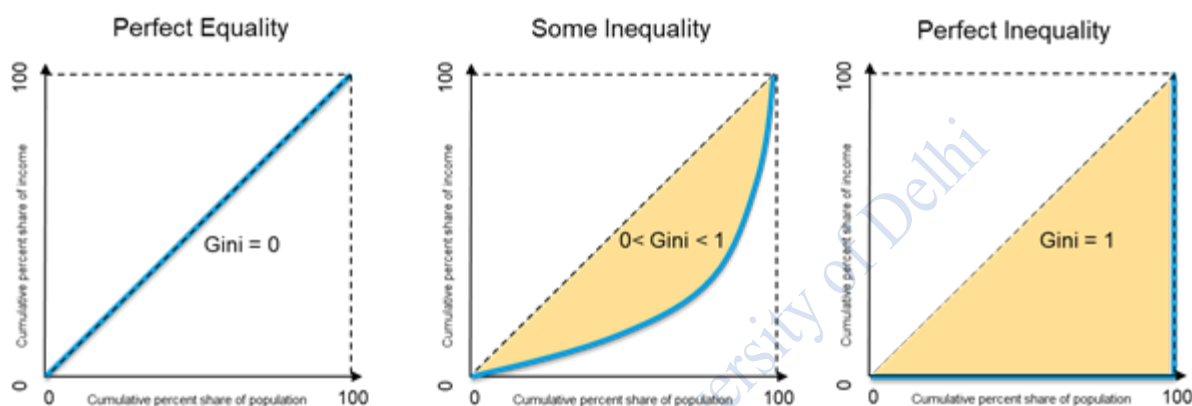


Figure 2



Features:

- i. The value of index varies between zero and one with 0 illustrating perfect equality and 1 representing perfect inequality (Refer Figure).
- ii. The coefficient allows direct comparison of the income distribution of two populations, regardless of their sizes.
- iii. It is not easily decomposable or additive.



Source: International Monetary Fund

There are number of statistics used to measure the inequality such as Hoover Index, Theil Index, Kuznets Ratio, etc. But the measures used above are the most flexible and useful for measuring inequality.

10.11 INEQUALITY IN INDIA: PATTERNS AND TRENDS

In order to understand the inequality in India, we begin our analysis using standard indicators of consumption and income. While consumption and income measure a flow of resources over a period of time, wealth (usually measured as net worth) refers to a stock of resources at a particular time period. Between consumption and income, consumption is seen as a more accurate reflection of life standards, as households tend to smooth consumption flows over time. Consumption data is also easier to collect in economies with very large informal sectors. Throughout this section, data availability and quality warrant caution before drawing firm conclusions on magnitude and trend of inequality.

10.11.1 Consumption Inequality

India has a long series of national household surveys to track household consumption since the early 1950s. In this unit, we rely on the rounds of the Indian National Sample Surveys



Organization, an organization under Ministry of Statistics and Programme Implementation to examine trends in levels of consumption expenditure in the population since the early 1980s. Table 8 provides the estimates of the various measures of inequality from the National Sample Survey Organization (NSSO) surveys.

Table 8 Trends in Consumption Inequality in India, 1983-2011

Income Group	1983-84	2004-05	2011-12
Share of Income Groups in Total National Consumption Exp.			
Top 20%	39.10	43.90	44.70
Top 10%	24.70	29.20	29.90
Middle 40%	22.2	20.30	19.60
Bottom 20%	9.00	8.50	8.10
Ratio of Groups			
Top 10% (Urban)/ Bottom 10% (Rural)	9.50	12.70	14.00
Top 10% (Urban)/ Bottom 10% (Urban)	7.00	9.10	10.10
Top 10% (Urban)/ Bottom 40% (Rural)	6.50	9.40	10.20
Gini Index			
Urban	0.31	0.36	0.38
Rural	0.27	0.28	0.29
Rural + Urban	0.30	0.35	0.37

Source: Ministry of Statistics and Programme Implementation, National Sample Survey (NSS) data.

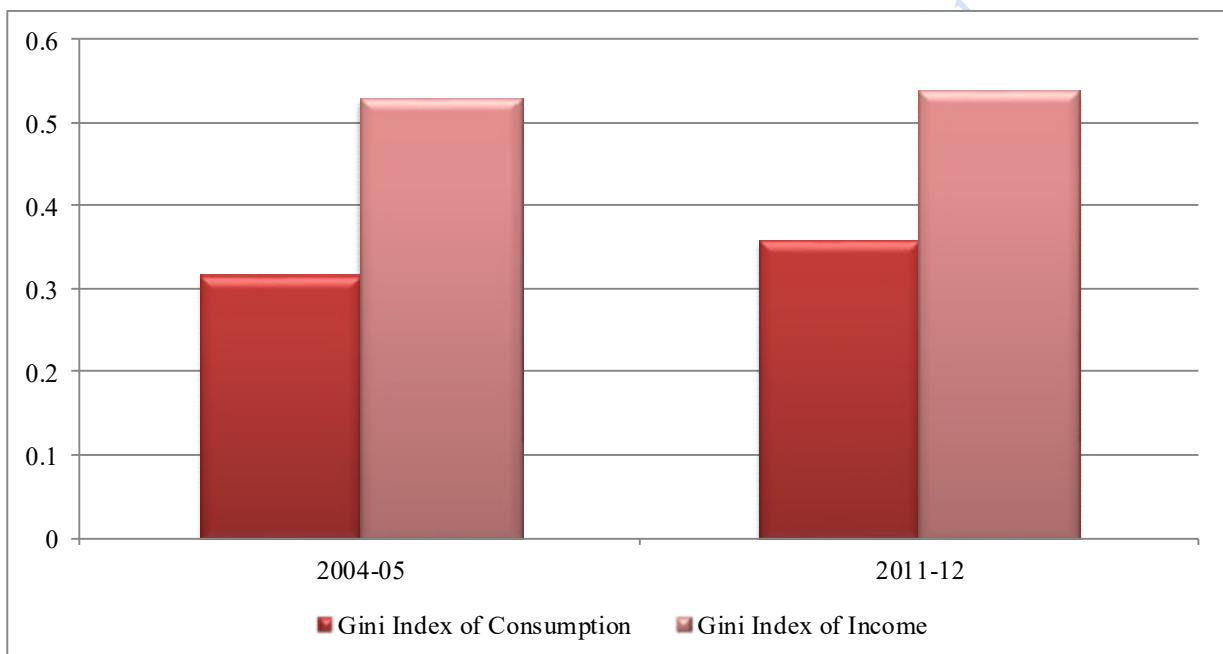
A commonly used indicator of inequality is the Gini index, which ranges from zero in a context of perfect equality to one representing perfect inequality. According to this measure, inequality has increased between 1983 and 2004-05 for both the rural and urban areas. The



inequality is more in urban areas than in rural areas. Post 2005, inequality increased slightly or remained stable. Other indicators that highlight the differences between the extremes of the consumption distribution, such as the ratio between the richest and poorest deciles, confirm the increase in inequalities during the period between 1993-94 and 2004-2005, and smaller increases thereafter. In 2011-2012, the richest 20% of the population accounted for nearly 45% of total consumption and bottom 20% for nearly 8.10%.

10.11.2 Income inequality

Figure 3 Inequality of Consumption Vs. Income



Source: India Human Development Survey Data and Working Paper on Inequality in India: A review of levels and trends by Himanshu (2019).

The income-based measure of inequality portrays a very different picture. Figure 3 reports the Gini indices of consumption and income inequality of 2004-05 and 2011-12 based on the India Human Development Surveys (IHDS). The IHDS is a nationally representative household panel survey which collects comprehensive information on consumption and income. Estimates based on this survey indicates that income inequality in India was around 0.54 in the financial year 2004-05 and 2011-12, with a marginal increase during this period. As in the National Sample Survey, consumption inequalities have increased over time, but are significantly lower than income inequality.



10.11.3 Regional Variation

Table 9 Gini Coefficient of distribution of consumption across States/ UTS, 1999-10

Range	1999-00		2009-10	
	Rural	Urban	Rural	Urban
0.20-0.25	Andhra Pradesh, Assam, Bihar, Gujarat, Haryana, Himachal Pradesh, Karnataka, Madhya Pradesh, Odisha, Punjab, Rajasthan, Uttar Pradesh, West Bengal	-	Assam, Bihar, Karnataka, Maharashtra, Odisha, Rajasthan, West Bengal	
0.25-0.30	Kerala, Maharashtra, Tamil Nadu	Gujarat, Haryana, Himachal Pradesh, Odisha, Punjab, Rajasthan	Andhra Pradesh, Gujarat, Haryana, Himachal Pradesh, Madhya Pradesh, Punjab, Tamil Nadu	
0.30-0.35	Nil	Andhra Pradesh, Assam, Bihar, Karnataka, Kerala, Madhya Pradesh, Maharashtra, Uttar Pradesh,		Assam, Bihar, Gujarat, Rajasthan, Tamil Nadu, Uttar Pradesh



		West Bengal		
0.35-0.40	Nil	Tamil Nadu	Kerala	Andhra Pradesh, Haryana Himachal Pradesh, Karnataka, Madhya Pradesh Maharashtra, Odisha, Punjab, West Bengal
0.40-0.45	Nil	Nil	Uttar Pradesh	Kerala
>0.45	Nil	Nil	Nil	Nil

Source: Government of India, 2010.

With regard to inter-state comparison of inequality in distribution of consumption measured by Gini Coefficient, it can be observed from Table 9 that there is a wide disparity in the two time periods viz. 1999-00 and 2009-10. Among the two time periods taken, the financial year 2009-10 has witnessed higher disparity as revealed from the Gini coefficient. The Gini Coefficient ranges from 0.20 to 0.40 in 1999-00. However, there was an incline in disparity during the FY 2011-12 where the Gini Coefficient range rises to 0.45. The table below shows the Gini Coefficient for 18 states excluding Arunachal Pradesh, Chhattisgarh, Goa, Jharkhand, Manipur, Meghalaya, Mizoram, Nagaland, Sikkim, Tripura and eight Union Territories of India due to non-availability of data. There are several points that need to be noted. First, there is a large variation in the Gini Coefficient across the states in both the financial years. Second, in the year 2009-10, the value of Gini Coefficient is highest in Uttar Pradesh and Kerala for rural areas and urban areas, respectively. Last, it is interesting to note that among 18 states, 8 states have witnessed an incline in rural inequality and 12 states experiences an incline in urban inequality between the financial years 1999-00 and 2011-12. Thus, the disaggregated analysis clearly reveals that exist wide disparities among states of India.

10.12 SUMMARY

The unit deals with the various aspects of poverty and inequality at both the national and state level. The United Nations Development Programme and World Bank are the two-leading



organisation for fighting against poverty and inequality. According to the World Bank, poverty results from “a lack of access to assets, insufficient or inappropriate economic growth, and poor governance”. There are various other factors, other than income and assets; which leads to poverty; for instance, the access to basic education, drinking water and sanitation and health care facilities etc. In order to estimate poverty in India, several committees were constituted both before and after the independence. In the pre-independence era, Dadabhai Naoroji was the first to talk about the line in India. In the post-independence era, several attempts have been undertaken to identify the proportion of poor people in the country. For instance, the erstwhile planning commission now referred to as National Institution for Transforming India set up a Y K Alagh Committee in 1979. In 1993, another committee known as Lakdawala Committee was formed. In 2012, Rangarajan committee was constituted for the same vision. Besides the erstwhile planning commission, many economists, research scholars and individuals have attempted to develop alternative methods to measure poverty. Some of these are Head Count Ratio, Squared Poverty Gap and Sen Index etc. Further, analyzing the pattern and trends at all India level, it was seen that the proportion of population below the poverty line was around 55 per cent in 1973-74. In the financial year 2011-12, it has fallen to 22 per cent. Considering the disaggregated analysis, although there has been a decline in the number and proportion of population below the poverty line but was not very encouraging in some of the states.

Inequality is a broader and complex concept than the Poverty. The inequality is measured using the various tools and techniques such as Range, Range Ratio, Palm Ratio, Atkinson Index, Lorenz curve and Gini Coefficient etc. During the period 1983-2011, inequalities have inclined for both the rural and urban areas. Considering the disaggregated analysis, the Gini Index of distribution of consumption used for measuring inequality reveals that there exist wide disparities among the states. Tackling inequalities is vital for reducing the extreme poverty at both the global and National Level. So, policy instruments targeted at providing universal access to education, housing, electricity, sanitation, nutrition and other essential services in order to eliminate the poverty and promote equality of opportunity among all.

10.13 GLOSSARY

Poverty Ratio: The head count ratio measures the proportion of population below the poverty line. It is used for comparing the poverty situation in two zones or two regions. It is expressed as percentage and mathematically defined as follows:

Head Count Ratio (HCR) = Total number of people below the poverty

-----* 100



Total Population

Poverty Line: The poverty line refers to minimum income, consumption or, more generally, access to goods and services below which individuals are considered poor.

Absolute Poverty: Absolute poverty is used to describe a condition in which an individual does not have the financial means to obtain commodities to support themselves.

Relative Poverty: Relative poverty refers to the standard of living compared to the economic standard of living in the same environment.

Lorenz Curve: Lorenz curve is used for the measurement of economic inequalities such as distribution of wealth and income between different countries or between different time periods.

10.14 ANSWERS TO IN-TEXT QUESTIONS

1. Relative Poverty	9. Migration
2. Rs.49.09(rural) and Rs.56.64 (urban)	10. False, Pakistani Economist Mahbub ulHaq created HDI in 1990.
3. UNDP and World Bank	
4. True	
5. National Institution for Transforming India	
6. Sen-Shorrocks-Thon Index	
7. Health, Education and Living Standards	
8. 22 per cent	

10.15 SELF-ASSESSMENT QUESTIONS

1. Elucidate the concept of Poverty.
2. Illuminate the difference between Absolute and Relative Poverty.
3. Briefly explain the various indicators for measuring poverty in India with the help of numerical examples. Also, explain how Squared Poverty Gap Index is more useful in estimating poverty situation?



4. Explain the poverty trends in India during the period 1973-2011. Highlight the main causes of poverty in India.
5. Define Inequality. Briefly explain the causes of inequality in India.
6. Briefly explain the patterns and trends of inequality in India during the period 1983-2011.
7. Demonstrate the use of Lorenz curve in measuring inequalities with the help of diagram.
8. Explain the inter-state scenario of disparity in consumption pattern in India during the period 1999-2011.
9. Draw the Lorenz curve for the comparison of profits of two groups of companies, C and D. What is your conclusion?

Total Amount of Profit earned		
	Group C	Group D
700	6	2
2600	12	20
7000	13	28
8500	15	15
11500	18	15
16000	20	14
18000	11	7
50000	14	8

10.16 REFERENCES

- Deaton, A., & Dreze, J. (2002). Poverty and Inequality in India A Re-Examination. *Economic & Political Weekly*, 37(36), 3729–3748.



- Introduction to Inequality. Retrieved from <https://www.imf.org/en/Topics/Inequality/introduction-to-inequality>
- Mahendra Dev, S., & Ravi, C. (2007). Poverty and Inequality: All-India and States, 1983–2005. *Economic and Political Weekly*, 2(6), 509–521.
- Ministry of Rural Development. (2020). *Poverty Measurement in india*. Retrieved from https://rural.nic.in/sites/default/files/WorkingPaper_Poverty_DoRD_Sept_2020.pdf
- Rangarajan Committee. (2014). *Report of the expert group to review the methodology for measurement of poverty*. Government of India.
- Socio-Economic Statistical Data and Facts about India: Indiastat. (2000). Retrieved from <https://www.indiastat.com/>

10.17 SUGGESTED READINGS

- Pindyck R. S. & Rubinfeld D. L. (2018). *Microeconomics* (Ninth). Pearson.
- Krugman P. R. & Wells R. (2021). *Microeconomics* (Sixth). Worth. Retrieved August 15, 2022.



LESSON 11

INDIVIDUAL DECISION

STRUCTURE

- 11.1 Learning Objectives
- 11.2 Introduction
- 11.3 What are Games of Strategy>
 - 11.3.1 Some Examples of Strategic Games
 - 11.3.2 Basic Terminologies
 - 11.3.3 Assumptions
- 11.4 Types of Game
 - 11.4.1 Sequential and Simultaneous Games
 - 11.4.2 Total Conflict and Commonality Games
 - 11.4.3 One Time and Repeated Games
 - 11.4.4 Asymmetric and symmetric information games
- 11.5 Representation of games
 - 11.5.1 Matrix Form
 - 11.5.2 Extensive Form
- 11.6 Summary
- 11.7 Glossary
- 11.8 Answers to In-Text Questions
- 11.9 Self-Assessment Questions
- 11.10 References
- 11.11 Suggested Reading

11.1 LEARNING OBJECTIVES

After reading this lesson, student will be able to:

1. Understand the difference between individual decisions and strategic interaction



2. Familiarize oneself with the concept of strategic decisions – their meaning and importance
3. Learn about different kinds of games
4. Illustrate games in normal and extensive forms

11.2 INTRODUCTION

Till now we have focused our discussion on individual decisions, that is, on what basis does an individual makes its choices. You may now already know that it is due to the scarcity of resources that individual consumers as well as producers are forced to make a choice. Had there been unlimited resources, the problem of choice wouldn't arise. You are now also familiar with the concept of marginal benefit or utility. Generally, an individual tries to maximize their own Marginal benefit, given some costs. You may also be aware how individuals respond to incentives when taking a decision. Incentives are an important feature that encourages or discourages certain behavior. Price is the one of the main incentives for a producer; whereas marginal utility may be an incentive for a consumer to buy a product. If the government would like to discourage the production and consumption of certain goods or services, such as alcohol, it may impose taxes on both producers and consumers. Whereas to encourage the production or consumption of a certain good or service, such as education, the government may provide subsidies to both producers and consumers.

When we study about individual decisions, we generally assume that there is no other influence on the individual decision. For instance, in the case of a perfectly competitive market, we simply overlook the actions of rival firms and assume that the actions of the rival firms do not impact any other firm in any way. In the case of a monopoly too, the fundamental feature is that a monopolist has no rivals. However, we very well know that we rarely encounter such extreme cases in real life. These are simplified cases that are used to draw generalized insights. But what about oligopoly markets? You may recall that oligopoly markets are market structures in which few large firms dominate the market. The other important feature of oligopoly firms, that we have highlighted in our earlier lessons, is 'interdependence.' The oligopoly firms are interdependent on various firms in decision making. This means that every firm has to take into account the reaction of the competing firm when making a decision and so each firm cannot take any decision independently.

In a strategic interaction, an individual's decision may depend upon on the decision of the other individuals. There may be interdependence in individuals' decision, and they are no longer solely chosen based on what is best for them. It is possible that someone else's



decisions impact your benefits, and your choices could impact someone else's utility. Hence, by the term 'strategic' we mean a situation in which when an individual chooses among alternative actions, he/she also considers how others will respond to his/her actions.

In this lesson and the following lesson, we will delve deeper into such strategic interactions between two or more participants—a study that is popularly known as 'Game Theory.'

11.3 WHAT ARE GAMES OF STRATEGY?

Most games comprise of skills, chance and strategy in different proportions. Like, tossing a coin is a pure chance game. The way you interact with others is a part of your strategic thinking, as in a volleyball game there are two teams, one team hit the ball over the net then the second team guesses where the ball land will. So, the way you consider what other player is thinking, other player is also taking into consideration what you are thinking. In game theory, when individuals behave rationally, it is like an interaction of rational decision makers. Individuals behaving rationally means they take all factors into account like their preferences, limitation, objectives, their constraints and their past experience before making any decision.

11.3.1 Some Examples of Strategic Games

As the name suggests, you may think that Game theory is only applicable in games such as poker, chess and tic-tac-toe and sports such as volleyball, table tennis or cricket. However, you must note that it is a quite crucial concept applied in many other walks of life too. If you reflect upon your actions, you will realize how you too engage in strategic interactions in everyday life.

- **Who goes grocery shopping?** Suppose there are two students – Joy and Happy who share an apartment in a city. One day Joy notices that the containers of rice, wheat flour and some lentils are almost empty. Although both Joy and Happy have decided to share the expenses equally, there is no consensus on who will go for grocery shopping. Since shopping involves a lot of time, no one wants to spend that time on shopping, and both wait for the other person to lose patience and go shopping. Here, both have only two choices- to go shopping or not. The best situation for Joy would be if Happy goes grocery shopping, and he gets to spend time doing what he loves – play computer games. Whereas the worst situation for Joy would be if he has to go shopping and misses out on playing games. Same goes for Happy. In the ideal case, one of them should shop for groceries. However, in case, on the way back from classes, both Joy and Happy decide to shop (without letting the other person know)



then there may be duplication of efforts and items and some perishable items may rot. On the other hand, if none of them shops for groceries, waiting for the other person to shop, then they might have to face an emergency situation in case an essential item runs out. Such a situation could also lead to disputes among the flat mates. Now this is an example of game theory where given the set of incentives, both have to decide their actions (strategies) keeping in mind other person's actions as well.

- **Which tire was punctured?** There is another example that is well known as a joke among students and teachers alike. It is a story of two friends who take Economics classes together. Since both the students are relatively bright in their studies, they decide to attend a music concert just a day before their Economics internal exam. They had already studied for the exam beforehand, so they planned to return home before midnight and revise their topics and give the exam next morning. However, everything did not go as per the plan. After the concert, they became so tired that they overslept in the morning and reached the exam hall late. The two friends decided to make up a story in front of the professor and get away with an excuse. They told the professor that they had gone to the university library to study and had planned to come back in time, however, on their way back they noticed a punctured tire in their car. They did not have a spare tire, so they had to spend most of the night looking for help. The professor allowed them to give the test tomorrow at the same time. The next day, both the friends were seated in separate rooms and the question paper contained only one question – which tire was punctured? The important strategic question that arises here is that if the friends are unprepared beforehand, would they be able to produce a consistent lie or not. Had you been in their place, what would've been your strategy? In this situation, you not only have to think about your own response but have to also consider the thinking process of your friend. Logically you may think that puncturing of one of the front tires is more probable, however, would your friend also be thinking on the similar lines? Similarly, your friend will also be thinking about your probable answer. So here, logic does not matter as much as giving the same answer as your friend does. Given the incentive of maintaining a good reputation with your professor, once again both the individuals must decide their strategies considering the other person's strategy.
- **Why are professors so strict?** Many professors, while taking an assignment or a term paper, specify a last date and strictly say that late submission is not acceptable. The students feel how heartless the professor is. The question that arises here is, why are the professors so strict? Initially, there may be some professors, who are kind and



are willing to accept late submissions if there are reasonable excuses. But the real problem lies in finding what the reasonable excuse is because in this way every other student would give some excuses, as they know professor is kind and will not be able to distinguish whether the excuse is reasonable or not. This will result in postponement of submission of assignments. So, the only strategic decision a professor can take is to not accept any excuses. The kind-hearted professor can behave hard by claiming that it is a university-wide guideline, so I cannot help you in it or she can say “if I do this for one person, I will have to do it for all which is not feasible” or she can acquire a character of hardness by acting like it a few times. This harsh behavior may be displeasing for her, but it will help her and the students in the long term.

There are many more real-life applications of game theory. Not only economists, but political scientists, sociologists, psychologists, mathematicians, among others, to use game theory concepts to analyze a variety of problems ranging from the behavior of competitive firms to voting and political decisions to social negotiations and collective bargaining. Strategic thinking is also essential in businesses and certain political decisions and even during wars.

Let us begin with the basics of game theory.

11.3.2 Basic Terminologies

- **Player:** A player is a participant in the game with respect to choosing a particular course of action. It is assumed that each player has the necessary skills to choose the action given the constraints.
- **Strategy:** A strategy is an action plan for playing the game; it may be a simple action or a complex action that may be dependent on earlier action and reaction of the player. There are two types of strategy:

- (i) **Pure strategy:** Each player is given a set of strategies, if a player chooses to take one action with probability one, then that player is playing a pure strategy. Like player 1 is choosing between head and tail. Either player 1 chooses heads with 100% probability or tail with 100% probability.
- (ii) **Mixed strategy:** in strategic game when the player does not choose one definite action, but rather chooses according to the probability distribution over his action. Like 60% chance that he chooses movie and 40% chance that he chooses match.

As in purely simultaneous move game, that we will discuss later, both players have to make decision at the same time, so they make their strategy by assuming what the other player will choose. Whereas in sequential game in which one



player moves first and other player move later so, who moves later makes its strategy depending upon the action taken by the first player.

- **Payoff:** An action plan when implemented results into a payoff i.e., it is a return to a player at the end of the game. It is a gain or loss that accrues to a participant that can be in monetary terms (such as profit, interest, dollar and so forth) or non-monetary in nature (such as utility, emotion and so forth). Every player wants to maximize their payoffs as it is the thing that they care about most.
- **Equilibrium:** When each player's rational strategies interact, we reach an equilibrium point. Such a strategic choice provides no incentive to a player to deviate once chosen. We will discuss the equilibrium of simultaneous and sequential games later in the chapter.
- **Zero sum games:** a game in which, if one side loses, then the other side wins, and the net change in wealth is zero.

11.3.3 Assumptions

- **Rationality:** Each player's motive is to maximize its payoff, and this depends upon how good the player is at choosing the best strategy based on his own interest. For this we assume that players are rational i.e., they take into consideration the entire set of action, involving the reaction and counteraction of their decision. Each player believes that rivals being rational and shall be taking decision to maximize their payoff. All these facts shall be taken into consideration when participants agree to choose a particular strategy.
- **Common knowledge of rules:** We assume that at some level in the game, players have a common knowledge of rules. These rules consist of (i) number of players in a game, (ii) strategies available to all players, (iii) payoffs, (iv) assumption that participants are rational in decision making.

IN-TEXT QUESTIONS

1. Match the following:

A	Strategy	1	Intersection of players' rational strategies
B	Equilibrium	2	Participant in the game
C	Payoff	3	Action plan for playing the game
D	Player	4	Return to a player at the end of the game



Ques 2: True or False:

- A. In a strategic interaction, an individual's decisions depend only on his own actions.
- B. The study of strategic interactions among rational individuals is known as game theory.

11.4 TYPE OF GAMES

The games can be classified into 4 broad groups based on their features:

- a) Sequential and Simultaneous games
- b) Total conflict and Commonality games
- c) One time and repeated games
- d) Asymmetric and symmetric information games

11.4.1 Sequential and Simultaneous Games

As the term suggests, the games in which the players move sequentially is called a sequential game. In such a game one player moves first, followed by the other player. Whereas in simultaneous games, both the players move simultaneously, that is, at the same time. Making such a distinction is essential since this could influence the strategy a player would decide. In a sequential game, all the firms have to think about the possible reaction of the other firm when it picks one strategy. In such a game, although the first mover is said to have an advantage over the others, it is well appreciated that the follower firms (who move later in the game) too have an advantage of complete information that the first firm lacks. Say two toothpaste companies are deciding upon the strategies to adopt to increase their sales in a city. Both firms evaluate the strategies they can implement and the possible reaction of their competitor. Now, being a sequential game, one firm decides first to advertise its product on national television. This move instantly increases the firm's market share, and hence its revenue. Considering the first move taken by the first firm, the second firm now gets to decide its strategy to compete for the market share.

On the other hand, in a simultaneous game, both the firms must think about the opponents move and decide their own moves at the same time. No player can observe the other players' choices beforehand. This makes the situation trickier. Let's consider the example of the two toothpaste companies again. Now, instead of one firm making the first move, both firms must decide their strategy at the same time. Hence, it may be possible that both the firms decide to advertise their products on the television, however it is also likely that one chooses to



advertise and the other chooses a different strategy like a discount or buy one get one free offer, etc.

Some of the most common sequential games are chess, scrabble and a popular simultaneous game is rock, paper, scissor. Citizens of a country voting for a political party is also an example of a simultaneous game, since all the voters submit their vote at the same time and no individual knows in whose favor the other individual has voted for.

11.4.2 Total Conflict and Commonality Games

We differentiate between various games based on the ultimate gain/loss that the players receive. In games of total conflict or “games of pure competition,” there is a clear distinction between a winner and a loser. Such games are referred to as ‘zero-sum games’ as one person’s gain is another person’s loss. If one person wins, the other loses, making the end result zero. In some cases, the result may not be exactly equal to zero, but a constant term. Such as in gambling, the total amount gambled remains the same, although the distribution of the money among the players could shift throughout the game.

However, in real life we come across several instances where the games are neither zero-sum nor constant sum. At times all the players are winners, or all are losers. Take the example of a war, where both the parties suffer massively, and both the sides end up being losers. On the other hand, international trade allows all the trading countries to benefit and so all are winners.

Games need not always be played under conflict. Co-operation among players is demonstrated to be beneficial to both the parties. Yet, in co-operative games the players have an incentive to cheat in order to attain personal gains. You will study later in the course how such a behavior is not only damaging to the cheating firm but has a negative impact on all the other firms too.

11.4.3 One Time and Repeated Games

Games could be played once or could be repeatedly played with the same players. If you think carefully, you’ll realize that one-time games are easier to be a part of since here, the players do not have to consider the long-term reaction of other players. This could lead the players to behave in their self-interest. On the other hand, repeated games are a bit more complicated. When a game is played again and again with the same players, the notion of reputation and co-operation sets in. This could have a major influence on the outcome of a game. If both players played repeated games, so if in first game a person defaults, then there



is a high chance that in next game the other person will default, so we will see that in repeated games cooperation among players is held.

11.4.4 Asymmetric and Symmetric Information Games

In a perfect world, information symmetry would mean that all the players have complete and equal knowledge about their own preferences as well as other players' strategies. However, that is not the case in the real world. Not only do players have incomplete knowledge about the impact of their own moves, but the players are also usually ill-informed about the other players' strategy. In a world with asymmetric information, the players have an incentive to conceal or fake their strategy in order to mislead the other players in the game. For example, a firm could deter the entry of new firms in the market by declaring fake price-war threats.

IN-TEXT QUESTIONS

3. Distinguish between sequential and simultaneous games.
4. If in a game with two players i.e., Deepak and Gourav, loss of Gourav is a gain of Deepak, then what kind of a game is it:
(A) Unfair game (B) Zero sum game (C) Constant sum game
5. In the well-known rock, paper, and scissors game, how many players are there? Is it simultaneous, or a sequential game?

11.5 REPRESENTATION OF GAMES

Given the number of players, strategies, and payoff we will learn here how to represent the games in order to find the solution. There are two ways to represent the game, one is normal form, other is extensive form.

11.5.1 Matrix Form

The normal form of a game is popularly known as a payoff matrix. In this form, we present a game in a tabular format.

The dimension of the table must equal the number of players and the strategies are shown in the row and column heading. In a two player and two strategy game, we usually begin by writing the strategies of player 2 in columns and strategies of player 1 in rows. Each cell within the table shows the payoff available to the player i.e., there are two numbers in a cell, the first number is a payoff of player 1 and second number is a payoff of player 2. Following is a general Payoff matrix:



Figure 1:

		PLAYER 2	
		Strategy A	Strategy B
PLAYER 1	Strategy A	p_{1A}, p_{2A}	p_{1A}, p_{2B}
	Strategy B	p_{1B}, p_{2A}	p_{1B}, p_{2B}

Here, both the players can choose between strategies A or B. If both the players choose strategy A, then the payoff will be (p_{1A}, p_{2A}) where p_{1A} is the payoff of player 1 and p_{2A} is the payoff of player 2. Similarly, if both the players choose strategy B, then the payoff will be (p_{1B}, p_{2B}) , where p_{1B} represents the payoff of player 1 and p_{2B} represents the payoff of player 2. In case player 1 chooses strategy A and Player 2 chooses strategy B, then the payoff is (p_{1A}, p_{2B}) , whereas if player 1 chooses strategy B and Player 2 chooses strategy A, then the payoff is (p_{1B}, p_{2A})

To make the concept clearer, consider the following payoff matrix with two players- Player one and two:

Figure 2:

		Player 2	
		Left	Right
Player 1	Top	2,3	3,5
	Bottom	4,2	5,1

In this example player 1 can choose between top and bottom row and player 2 can choose between left and right column. If player 1 chooses bottom row and player 2 chooses left column, then the payoff will be $(4,2)$ where 4 being the payoff of player 1 and 2 being the payoff of player 2. Similarly, when player 1 chooses top row and player 2 chooses right column payoff will be $(3,5)$, where 3 represents the payoff of player 1 for choosing top row and 5 represents the payoff of player 2 for choosing the right column.



Note: When creating a payoff matrix, it is important to first identify the players and their strategies. Once you have both, start entering the payoffs in a matrix.

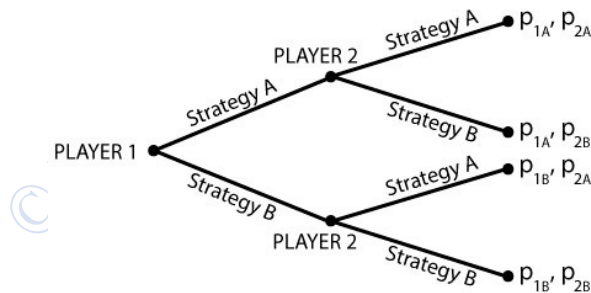
11.5.2 Extensive form

Another way to represent games is known as Extensive form or a Game tree. Sequential games are often represented in the form of a Game tree.

The starting point of the game is called a node. In sequential games, when one player makes a move from the initial node, it moves along a branch which shows the order of move and reaches the end of the branch, termed as a decision node. Each node represents the decision point of the player. When the second player chooses its strategy, it moves along another branch extending from the decision node to end of the branch, termed as the terminal node. The terminal node also corresponds to the end of the game, that is, no further decisions can be taken by the players. The payoffs are written at the end of the terminal node, where the first figure represents the payoff accrued to the first player and the second figure represents the payoff accrued to the second player.

Following is an example of a game tree with two players- Player 1 and 2. If player 1 chooses strategy A and player 2 also chooses strategy A, then the payoff is (p_{1A}, p_{2A}) where p_{1A} is the payoff of player 1 and p_{2A} is the second player's payoff. Similarly, if player 1 chooses strategy B and player 2 chooses strategy A, then the payoff is (p_{1B}, p_{2A}) where p_{1B} represents the payoff of player 1 and p_{2A} represents the payoff of player 2.

Figure 3:

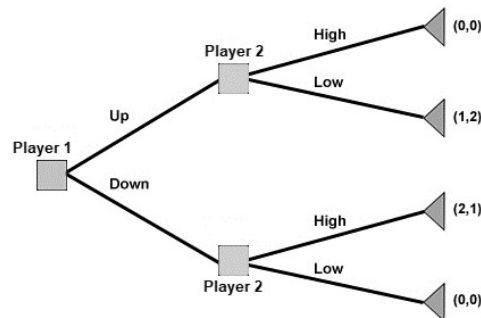


The following is an example of a game tree with two players- 1 and 2. Player 1 has two strategies to choose from- up or down. Whereas player 2 can choose from the two strategies- High or Low. If player 1 chooses strategy – Up and player 2 chooses High, then the payoff is $(0,0)$ that means both the players will get 0 in return. Similarly, if player 1 chooses Down and player 2 chooses Low, then again, the payoff is $(0,0)$. If player 1 chooses Up and player 2 chooses Low, then the payoff will be $(1,2)$, 1 being the payoff of player 1 and 2 being the



payoff of player 2. On the contrary, if player 1 chooses Down and player 2 chooses High, then the payoff is (2,1) where 2 represents the payoff of player 1 and 1 represents payoff of player 2.

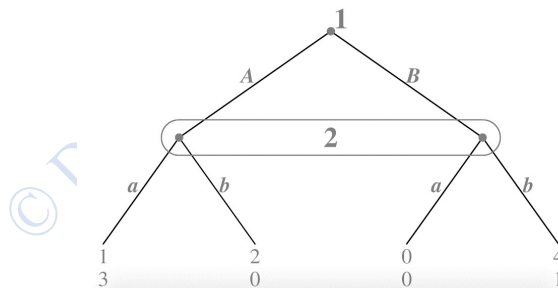
Figure 4:



Game trees can take different shapes based on the number of players, number of strategies and number of moves.

In simultaneous games, both players make decision at the same time. To represent a game in this form, we choose one of the players to play the role as a second player and connect his decision node with dotted oval around the neck to show that he is not really a second player. Following is an example of a simultaneous game tree:

Figure 5:



We will learn about simultaneous and sequential games in detail in the next lesson.

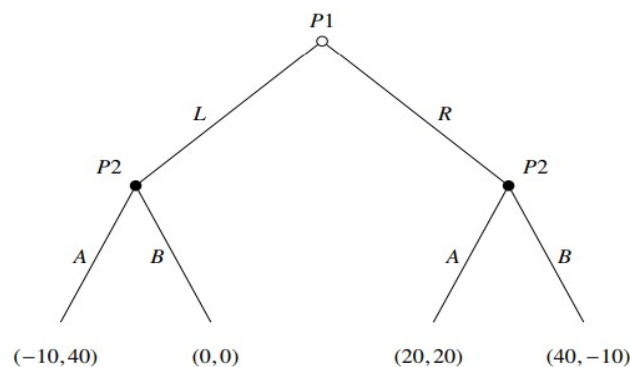
IN-TEXT QUESTION

6. Create a payoff matrix using the following information:
Two companies – A and B share a market, and both need to determine whether they should advertise or not. If both A and B don't advertise, they each get 5 units of



additional revenue. If both advertise, they gain only 3 units. If A advertises, but B doesn't, A gets an additional 6 units and B only 2 units, and conversely if B advertises and A doesn't, then B gets 6 units and A gets only 2 units of additional revenue.

7. Create a game tree for a sequential game using the following information:
 - A. Two players – A and B are playing a game in which Player one has two options to choose from – ‘up’ or ‘down’, whereas player two can choose from ‘left’ or ‘right.’ If Player one moves first and chooses ‘up’ and player two chooses ‘left’ then they receive (1,3). If Player one chooses ‘up’ and player two chooses ‘right’ then they receive (3,2). If player one chooses ‘down’ and player two chooses ‘left’ then they receive (4,2). If player one chooses ‘down’ and player two chooses ‘right’ then they receive (3,1).
 - B. SkyTech and AeroSafe are two airline companies that compete in the market. Both the companies are attempting to capture the market by setting a lower price of their services. Both the companies have only two strategies to choose from – Low price and High price. SkyTech, being an old company moves first in the game and AeroSafe moves second. If SkyTech chooses low price and AeroSafe too reduces its price, then both get 3000 units. If SkyTech chooses low price but AeroSafe continues with high prices, then SkyTech will earn 4000 units and AeroSafe will earn 2000 units. On the other hand, if SkyTech continues with high prices and AeroSafe chooses low prices, then SkyTech will receive 2000 units and AeroSafe earns 4000 units. If both continue with high prices, then both earn 3500 units.
8. Create a payoff matrix using the following game tree:





9. Create a game tree considering the first player producer as the first mover in the following payoff matrices:

		PACKERS	
		LOW QUALITY	HIGH QUALITY
PRODUCERS	LOW QUALITY	(0, 50)	(0, 0)
	HIGH QUALITY	(10, 10)	(40, 20)

11.6 SUMMARY

In this chapter we learnt about the difference between individual games and strategic games. In a strategic interaction, an individual's decision depends upon the decision of the other individuals. When an individual chooses among alternative actions, he/she also considers how others will respond to his/her actions. Then we looked at some real-life examples where there is a use of game theory. Then we discussed the types of games. In a sequential game, one player moves first, followed by the other player. Whereas in simultaneous games, both the players move at the same time. In the next chapter we will discuss simultaneous and sequential games in detail. Then we saw how given the number of players, strategies, payoff, games can be represented in normal form or extensive form.

11.7 GLOSSARY

Strategic decisions- Actions taken by an individual taking into consideration the responses of other players

Payoff- Return to a player at the end of a game

Pure strategy- if player chooses one action with probability 1

Mixed strategy- if player action associated with the probability

Repeated games- When game is played again and again with the same players

Zero sum game – It is a game in which one person's gain is another person's loss – making the result equal to zero.



Simultaneous games- A game where each player chooses their strategy at the same time, without knowing the strategy chosen by other players

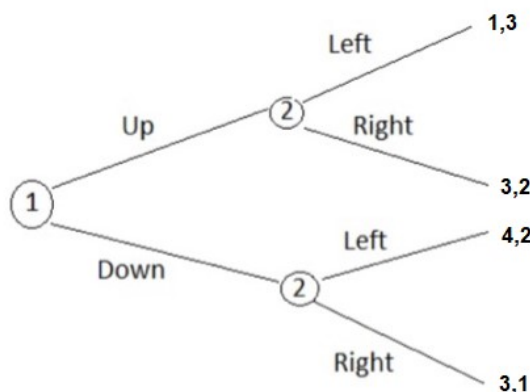
Sequential games- A game where the players take turns to choose their strategies. The player that moves second has more information than the player that moves first

11.8 ANSWERS TO INTEXT QUESTIONS

1. A = 3; B = 1; C = 4; D = 2
2. False B. True
3. In simultaneous games, players make their decisions at the same time and are unaware of the movements and actions of other players. Example: Stone, paper, scissor
In sequential games, players take turns to make their decisions. That is, one player moves first, followed by the other player. Example: Chess
4. (A) Zero sum game
5. There are two players. It is a simultaneous game.
- 6.

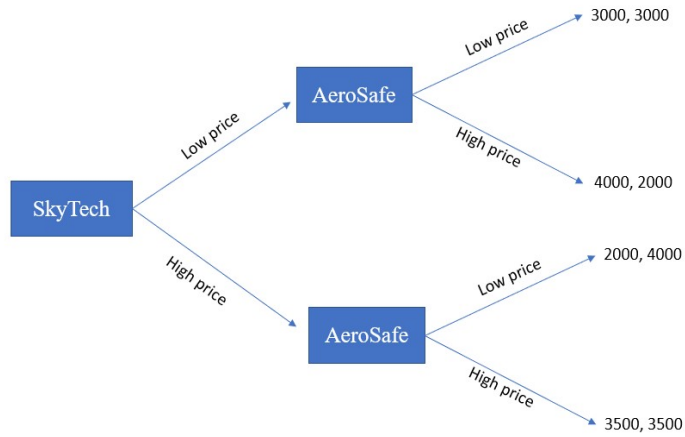
		Firm B	
		Advertise	Do not Advertise
Firm A	Advertise	3,3	6,2
	Do not Advertise	2,6	5,5

7. (A)





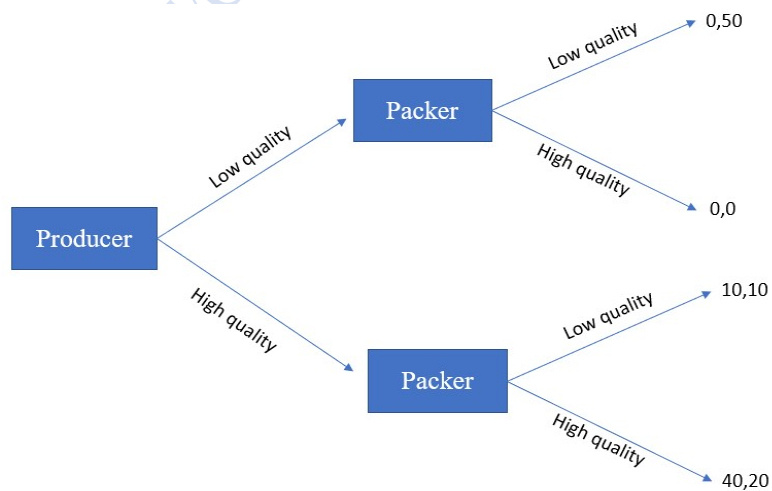
(B)



8.

		P2	
		A	B
P1	L	-10, 40	0, 0
	R	20, 20	40, -10

9.

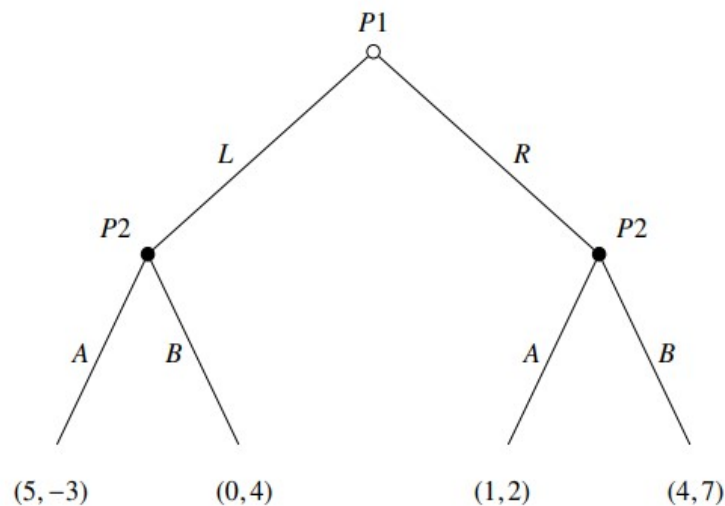




11.9 SELF-ASSESSMENT QUESTIONS

Ques 1) Distinguish between pure strategy and mixed strategy.

Ques 2) Create a payoff matrix using the following game tree.



Ques 3) Create a game tree considering the first player as the first mover in the following payoff matrix

		Firm 2	
		WHEAT	OAT
Firm 1	WHEAT	(-5, -5)	(10, 10)
	OAT	(10, 10)	(-5, -5)

Ques 4) Create a payoff matrix using the following information:

Loki and Mary do not like each other but have a lot of common friends. Both want to invite them to a dinner party either on Friday or Saturday evening. If both set the party at the same time, this will be considered a disaster with a payoff of -10 for both. If one plans the party on Saturday and the other on Sunday, then one having the Saturday party gets a payoff of 5, and the other of 4.



11.10 REFERENCES

- Dixit, A.K., Skeath,S.(2015). *Games of strategy*: Fourth international student edition. WW Norton & Company.
- Acemoglu, D., Laibson, D.,& List, J.(2017). *Microeconomics*.Pearson.
- Frank, R.H., & Cartwright, E.(2010). *Microeconomics and Behavior*. New York. McGraw-Hill.

11.11 SUGGESTED READING

- Osborne, M. J. (2004). *An Introduction to Game Theory*(Vol. 3, No. 3). New York: Oxford University Press.

© DDCE/COL/SOL/University of Delhi



LESSON 12

INDIVIDUAL STRATEGIC INTERACTIONS

STRUCTURE

- 12.1 Learning Objectives
- 12.2 Introduction
- 12.3 Simultaneous Game
 - 12.3.1 Nash Equilibrium
 - 12.3.2 Underline Best Response Payoffs
 - 12.3.3 No Nash Equilibrium
 - 12.3.4 Dominant Strategy
 - 12.3.5 Dominant Strategy of One Player Only
 - 12.3.6 Battle of Sexes
- 12.4 Sequential Games
 - 12.4.1 Solving Sequential Games
 - 12.4.2 Revisiting Battle of Sexes
- 12.5 Summary
- 12.6 Glossary
- 12.7 Answers to In-Text Questions
- 12.8 Self-Assessment Question
- 12.9 References
- 12.10 Suggested reading

12.1 LEARNING OBJECTIVES

After reading this lesson, students will be able to:

1. Understand simultaneous games
2. Find the Nash equilibrium of the game
3. Understand Dominant strategy and how dominant strategy does not imply that Nash
4. Equilibrium exists while the reverse i.e., presence of Nash equilibrium gave the evidence of dominant strategy



- 5. Understand sequential games
- 6. Solve sequential games

12.2 INTRODUCTION

In this chapter we will learn about the simultaneous as well as sequential games in detail. Simultaneous games are those in which players have no knowledge about the action chosen by other players, i.e., there is imperfect information. Players are just trying to figure out what the other player is going to choose and at the same time other players are also figuring out the same. There are two types of strategies the person can choose. One is pure strategy and other is mixed strategy. Here, we will discuss pure strategy in detail. In sequential game one player moves first and gets the first mover advantage. Then we will solve this type of game using backward induction.

12.3 SIMULTANEOUS GAME

In simultaneous game each player takes a decision at the same point of time and players have imperfect information, i.e., they don't know what other player is going to choose. For example, in an auction all bidders make their bid simultaneously and they cannot look ahead to know how others will react to their choice and similarly in rock, paper, scissor game, players have no information about the action of other players. A discrete strategy is one where there are a finite number of pure strategies like player 1 is choosing between head and tail. These strategies can be depicted in a payoff matrix or game table. The payoff table can be used for illustrating the payoff of any number of players, but the dimension of the table must equal the number of players. We can also use the extensive form to represent this game.

Let's take an example,

Figure 1:

		Player 2	
		Left	Right
Player 1	Top	2,3	3,5
	Bottom	4,2	5,1



In this example player 1 has two choices labeled Top and Bottom; player 2 two choices labeled Left and Right. Outcome is generated when any particular row and column is chosen. If player 1 chooses bottom row and player 2 chooses left column, then the payoff will be (4,2) where 4 being the payoff of player 1 and 2 being the payoff of player 2. Similarly, when player 1 chooses top row and player 2 chooses right column payoff will be (3,5), where 3 represents the payoff of player 1 for choosing top row and 5 represents the payoff of player 2 for choosing the right column.

12.3.1 Nash Equilibrium

In the above payoff matrix, given that player 1 chooses top, player 2's best response to player 1's choice of top is right because given player 1 chooses top, player 2 can choose between left or right, if he chooses left, he gets 3 as payoff and 5 if he chooses right. So, he is getting higher payoff when he chooses right, therefore it is his best response. Given player 1 chooses bottom, the best response of player 2 is left because player 2 gets higher payoff in choosing left. Similarly, we can find the best response of player 1 given the player 2 choices.

In **Nash equilibrium** each player wants to maximize its payoff and their choice depends upon what the other player is choosing. It is the strategic choice of each player, which provides no incentive to deviate from their initial strategy once chosen. So, it is the best choice for each player given the equilibrium strategy of the other player.

In the above example, let's check whether (Top, Right) is Nash equilibrium. If player 1 chooses top, player 2 can choose between left and right; he gets higher payoff in choosing right because in choosing right he gets 5 as payoff and in choosing left he gets 3 as payoff. So, right is the best response to player 1's choice Top. If player 2 chooses right, then player 1's optimal choice is bottom because he gets 3 as a payoff in choosing top and 5 as a payoff in choosing bottom. So, his best response to player 2's strategy is bottom. Therefore, (Top, Bottom) is not Nash equilibrium because it provides an incentive to player 1 to deviate from top to bottom.

Here, (Bottom, Left) is a Nash equilibrium. If player 1 chooses bottom, the best response of player 2 is left because given player 1's strategy 'Bottom', he gets 2 as payoff in choosing left and 1 payoff in choosing right and gets higher payoff in choosing left. If player 2 chooses left, player 1 can choose between Top and bottom, in top he gets 2 as payoff and in bottom he gets 4 as payoff, so he chooses bottom. Therefore, Bottom, Left is Nash equilibrium because it provides no incentive to player to deviate from this outcome.



NOTE: Rather than player 1's choice is optimal for all choice of player 2, we just require that it would be optimal for optimal choice of player 2 i.e., Player 1's choice is optimal given player 2's choice and player 2's choice is optimal for player 1's choice.

12.3.2 Underline Best Response Payoff

Underline best response payoff is one of the ways to find Nash equilibrium. There are following steps that we have to follow:

- (i) Underline the payoff corresponding to player 1's best response
- (ii) Underline the payoff corresponding to player 2's best response

You can start underlining with any player payoff. Let's assume, there is an event in the college Deepak and Amit are thinking whether they contribute some amount for the event or not. Look at the following payoff matrix to understand this concept:

Figure 2:

		Deepak	
		Contribute	Don't Contribute
Amit	Contribute	4,3	2,1
	Don't Contribute	1,2	0,1

Here we represented the game in normal form with two players. Deepak and Amit have an option to choose between contribute or don't contribute. If Deepak contributes, Amit's best response is to contribute. So, we underline the payoff Amit will receive by choosing to contribute as an option i.e., 4. Similarly, if Deepak doesn't contribute, Amit's best response is to contribute, in which he receives payoff 2 which is more than payoff of 0, which he gets from choosing not contributing as an option. So, we underline this payoff. In this way we have underlined the best response of Amit given the Deepak's choice.

Now we will underline Deepak's best response given Amit's choice. If Amit contributes the best response of Deepak is to contribute, in which he will receive the 3 as a payoff in comparison to 1 which he gets from choosing don't contributing as an option, so we



underline this payoff. If Amit doesn't contribute the best response of Deepak is to contribute because in this, he gets higher payoff i.e., 2, so underline this payoff.

Figure 3:

		Deepak	
		Contribute	Don't Contribute
Amit	Contribute	<u>4</u> , <u>3</u>	<u>2</u> , 1
	Don't Contribute	1, <u>2</u>	0, 1

In a cell where both the payoff is underlined is Nash equilibrium, here (Contribute, Contribute) is Nash equilibrium.

12.3.3 No Nash Equilibrium

There are situations where Nash Equilibrium may not exist. Just look at the following figure that is represented in a normal form to understand it better.

Figure 4:

		Player 2	
		LEFT	RIGHT
Player 1	TOP	0, 0	0, -1
	BOTTOM	1, 0	-1, 3

If player 1 chooses Top, player 2's best response is to play Left as his payoff 0 in case of choosing Left is higher than the payoff -1 in case of choosing Right. If player 2 chooses Left, player 1's best response is to play Bottom. Therefore, (Top, Left) is not Nash equilibrium because player 1's choice is not optimal given player 2's choice of Left, which is optimal for player 1's choice of Top.



Similarly, if player 1 chooses Bottom, player2’s best response is to play Right, if player2 chooses Right then player 1 chooses Top. Therefore, it is also not Nash equilibrium.

So, in this example no Nash equilibrium exists.

IN TEXT QUESTIONS

- Given figure 1 above, if player 2 chooses left, what is the best response of player 1?

		Firm 2	
		WHEAT	OAT
Firm 1	WHEAT	(-5, -5)	(10, 10)
	OAT	(10, 10)	(-5, -5)

- Solve for the Nash equilibrium in the following

12.3.4 Dominant Strategy

Consider again the earlier example that we discussed in Figure 2, of two college students Amit and Deepak and their strategies Contribute and Don’t Contribute. In that case (Contribute, Contribute) is Nash equilibrium. In that example you have noticed that whatever the Deepak chooses the Amit will be better off in choosing Contribute over Don’t Contribute. Similarly, whatever the Amit will choose the Deepak will be better off in choosing Contribute over Don’t Contribute. So, (Contribute, Contribute) is their dominant strategy.

Figure 2:

		Deepak	
		Contribute	Don’t Contribute
Amit	Contribute	4,3	2,1
	Don’t Contribute	1,2	0,1



Dominant strategy is one optimal choice of strategy for each player, in which no matter what other player does, he will choose only his optimal strategy.

NOTE: Dominant strategy and Nash equilibrium are two different concepts. Dominant strategy is the one optimal choice of a player irrespective of what another player chooses. If there are 2 players A & B, then player A is doing his best, irrespective of what player B does. In Nash equilibrium each player anticipates what its opponent will do and then decides to choose his best possible action. It results in stability in strategy. This is because once Nash equilibrium is attained, there is no incentive for any player to deviate from this Nash equilibrium.

Let's understand this concept with the most famous game i.e., **Prisoners' Dilemma**. It was introduced by A.W Tucker. Consider a storyline, where two suspects have been arrested under the suspicion of a crime. There is little evidence against them. The Superintendent of police places them in separate detention rooms, so that they can't communicate with each other. Each person has been questioned separately and each person has two strategies- to Confess or not to Confess. The authorities need evidence in order to convict an individual. Authorities tell them "If they both confess, they will be jailed for 5 years each. If one of them confesses then the person who confesses will be jailed for a shorter term i.e., 1 year for cooperating with the police, while the other will be jailed for 10 years. If both of them do not confess, they will be jailed only for 2 years.

This is a simultaneous move game with 2 players. The payoff matrix of this game can be represented in a matrix form i.e.

Figure 5:

		Suspect 2	
		Confess	Do not confess
Suspect 1	Confess	5,5	1,10
	Do not confess	10,1	2,2

In this game the lower the payoff will be the better for the person because payoff is the number of years they have to be jailed. Consider the game from suspect 1's perspective. He has to think about suspect 2's move. If he believes that suspect 2 will confess, then the best choice for him is also to confess because he will be jailed for a shorter period i.e., 5 years,



while denial (do not confess) results in 10-year jail. If he believes that suspect 2 deny (do not confess) then again confess will be the best response of suspect 1 because of lower term of jail i.e., 1 year whereas denial would lead to 2-year jail. So, regardless of what suspect 2 will chose the “confession” is a dominant strategy of player 1. Similarly, we look at the game from the suspect 2’s perspective. He has to think about the suspect1’s move. If he believes that suspect 1 will confess, then confession is better for suspect 2 because of jail for 5 years while denial would mean jail for 10 years. Therefore, he will choose to confess in this case. If he believes that suspect 1 will not confess, then he will confess because confession result in jail for 1 year in comparison to 2-year jail if denied. So, for suspect 2 confessions is the dominant strategy because whatever suspect 1 chooses it will be better for suspect 1 to confess. This is the case where both the player has a dominated strategy “confess”.

Now look at the Nash equilibrium: If suspect 1 does not confess then suspect 2 best response is to confess and if suspect 2 confess then suspect 1 best response is to confess. Therefore, it is not Nash equilibrium. However, if suspect 1 confesses then best response for suspect 2 is to confess because confess result in 5-year jail whereas do not confess would result in 10-year jail and if suspect 2 confess then suspect 1 will also confess. Therefore, (confess, confess) is a unique Nash equilibrium where both come jailed for 5 year each but is not a optimum choice because (do not confess, do not confess) is an improvement over the Nash equilibrium outcome because with this they both jailed only for 2 year each rather than the 5 year jailed each.

NOTE: From this prisoners’ dilemma game we can understand that Nash equilibrium is not always the best outcome; there can be better outcome than this outcome.

IN TEXT QUESTION

3. In dominant strategy each player chooses their best strategy given other players’ best response.

Check whether the above statement is true or false.

4. Nash equilibrium always leads to pareto efficient outcome.

Check whether the above statement is true or false. If false explain it with an example.

12.3.5 Dominant Strategy of One Player Only

In prisoners’ dilemma game we have seen that both suspects have dominant strategy, but it is not always the case that dominant strategy exists. There may be a scenario where only one



player has a dominant strategy, then the other player assumes that player 1 will use his dominant strategy and based on this player 2 can choose its best response.

Figure 6:

		Player B	
		Top	Bottom
Player A	Front	5,3	3,1
	Back	4,2	2,4

We will illustrate this with an example; there are two friends A, B. A will choose between Front and Back. B will choose between Top and Bottom.

Look at the dominant strategy of B. B chooses Top if it is believed that A will choose Front, and B will choose Bottom if he believes that A will choose Back. Therefore, no dominant strategy exists of player B.

If A believes that B is choosing Top, then its best response is to choose Front and if it believes that B will choose to bottom its best response is to choose Front. Therefore, Front is a dominant strategy of A i.e., whatever B chooses A the best response is to choose Front. Now, given A’s dominant strategy “Front”, B will choose its best response and its best response is Top. Therefore, (Front, Top) is a Nash equilibrium.

12.3.6 Battle of Sexes

In this game husband and wife want to go outside, they can go either for movie or for shopping. The husband prefers to go to the movie while the wife prefers shopping, both prefer to spend time together. So, if they go to a different place, i.e., alone then their payoff will be 0 each. However, if the wife goes shopping and the husband also goes shopping then the payoff of wife will be 3, whereas for husband it is 1 and if they go for movie, husband has higher payoff i.e., 3 and wife payoff is 1.

Figure 7:

		Wife	
		Movie	Shopping
Husband	Movie	3,1	0,0
	Shopping	0,0	1,3

NOTE: If dominant strategy exists then Nash equilibrium will also exist but having a Nash equilibrium does not guarantee that a dominant strategy will also exist. As in the above



example of battle of sexes where two Nash equilibrium exists that are (movie,movie) and (shopping,shopping) but no dominant strategy exists.

IN TEXT QUESTIONS

5. Do the following games have a dominant strategy? Specify if only one player has a dominant strategy, or both have dominant strategies.

(A)

		PACKERS	
		LOW QUALITY	HIGH QUALITY
PRODUCERS	LOW QUALITY	(0, 50)	(0, 0)
	HIGH QUALITY	(10, 10)	(40, 20)

(B)

		Firm 2	
		WHEAT	OAT
Firm 1	WHEAT	(-5, -5)	(10, 10)
	OAT	(10, 10)	(-5, -5)

12.4 SEQUENTIAL GAMES

So far, we have discussed simultaneous games where two players choose their strategies at the same time, having full knowledge about their own and the opponents' payoffs. But since the decisions are to be taken at the same time, the players are unaware of their opponents' final choices. However, in many situations the players move in a sequential order, that is, one player makes its decision only after the other player has picked its strategy. So, in this type of game, one player has full knowledge of the payoffs as well as the strategy of the other player.



If you try, you may recall many games you must have played in your childhood that are nothing but examples of sequential games. Think about chess, tic-tac-toe, and scrabble. Taking the example of chess forward, let us assume there are two friends- Akku and Bittu who have decided to play a game of chess on a summer evening. If Akku starts the game by moving one of the chessmen forward, in that case Bittu will observe the move and then decide the strategy going forward. In the next turn, Akku will observe Bittu's move and then choose the best move. The game continues in this fashion till either of the player checkmates the other.

There are many other examples of sequential games in the real world that may not be as straightforward as a game of chess. Suppose Ecolaza and Ecostic are the only soft drink manufacturing companies in the country. Now, to increase its demand and hence revenue, Ecolaza has decided to advertise its soft drink over television. The Ecolaza ads have become an instant hit among the public and many consumers who earlier consumed Ecostic, now switch over to Ecolaza. While the revenue and eventually the profits of Ecolaza increase, the market share of Ecostic declines. In view of the dwindling demand, Ecostic plans to change its strategy and starts advertising aggressively over television as well as on radio. The change in strategy works in Ecostic's favor as it regains its market share. In this example, we can see how Ecostic adopted a strategy only after observing its competitor- Ecolaza's strategy.

Now consider the above example of Ecolaza and Ecostic again. Say a new cola brand- ThunderCo is planning to enter the market which currently is entirely captured by the two companies. Ecolaza waits and allows ThunderCo to make a decision—whether to enter the market or not. Let's assume that ThunderCo decides to enter the market and competes for market share. Now taking this move into account, Ecolaza has two choices- either to allow and accommodate ThunderCo to capture one-third share of the market, or to fight it by making it difficult for the new firm to operate in the market. Here, Ecolaza can fight by lowering its prices to levels that ThunderCo cannot compete with. Now, Ecolaza would move forward with that strategy which gives it the maximum return (payoff), which we will discuss in detail later. Hence, we see that Ecolaza makes a move only after ThunderCo has taken a decision. This is clearly a sequential game.

Economists are usually more interested in sequential games since these games are representative of reality, more than simultaneous games.

If you think about sequential games deeply, you would be able to draw two important inferences:



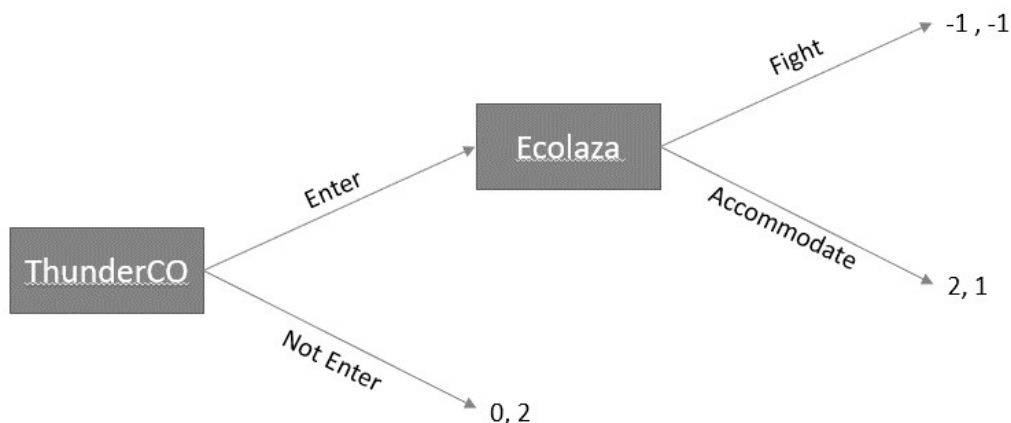
1. The player that moves first, enjoys a ‘first-mover advantage.’ This means that often, the player that gets to make the first move can influence the flow of the game in its own favor and can earn more returns. So, first-mover advantage refers to the competitive advantage that a firm can gain by moving first in a game.
2. The player that moves later has additional knowledge about the strategies of other players. Such a player can, therefore, make an informed choice and can make a better decision based on the action of other players.

12.4.1 Solving Sequential Games

Sequential games are commonly depicted in the form of Game trees.

Our earlier example of Ecolaza and ThunderCo can be represented as a game tree as follows:

Figure 8:



A game tree can be solved by the method known as ‘Backward induction.’ In this method, we start analyzing the terminal node first, and then move to the left. In other words, we first consider the second player’s strategy. The second player will choose that strategy which gives him the maximum payoff. Now based on the strategy chosen by the second player, we determine the best strategy that player 1 can choose.

In this example, we’ll first look at Ecolaza’s strategy. Ecolaza has only two options- to either fight or accommodate the entry of ThunderCo. So, if ThunderCo chooses to enter the market, the best strategy Ecolaza has is to accommodate the entry since it receives the payoff 1, which is better than the payoff Ecolaza will receive if it chooses to fight (-1). Now if ThunderCo



knows the payoffs that both the companies will receive, then it can easily predict that if ThunderCo enters into the market, Ecolaza will end up accommodating the entry since it is beneficial for Ecolaza. So essentially, ThunderCo has to now make a choice between entering or not entering the market, with payoffs for each strategy as 2 and 0 respectively. 2 being greater than 0, ThunderCo will choose to enter into the market. This is also the Nash equilibrium of the game.

We can also represent the game in a matrix form in the following manner:

Figure 9:

		Player 2: Ecolaza	
		Accommodate	Fight
Player 1: ThunderCo	Enter	2,1	-1,-1
	Not enter	0,2	0,2

The game tree as well as the payoff matrix illustrates the same story. If the first player, i.e., ThunderCo decides to not enter the market, it will earn zero revenue, whereas Ecolaza will continue to earn 2 units of revenue. However, if ThunderCo decides to enter the market, then Ecolaza will have two options, either to accommodate or to fight the entry of ThunderCo. If Ecolaza accommodates the entry, it will earn 1 unit of revenue and ThunderCo will earn 2 units of revenue. On the other hand, if Ecolaza decides to fight by reducing its price, then both the companies will earn negative returns -1. Note that in both cases, Ecolaza suffers a net loss as compared to the case when ThunderCo decides not to enter the market.

If Ecolaza wishes to maximize its revenue, then in response to ThunderCo entering the market, Ecolaza will do the best and accommodate the entry. Knowing that if ThunderCo enters the market, Ecolaza will accommodate its entry, it is best for ThunderCo to enter the market and earn 2 units of revenue than to decide to not enter and earn zero revenue.

Note here that in case Ecolaza makes a fake threat that if ThunderCo enters into the market, it will fight the entry by slashing its price, then in such a case, it is better for ThunderCo to refrain from entering the market and earn zero returns than to enter the market and earn negative returns.



Hence, in this game we have 2 Nash equilibria: (Enter, Accommodate) and (Not Enter, Fight) with payoffs (2,1) and (0,2).

In a sequential game, if the player that moves first obtains more benefits than the players that move later, then we say that the first player enjoys a ‘first mover advantage.’ In the above example, if ThunderCo moves first and decides to enter into the market, then it earns 2 units whereas Ecolaza earns only 1 unit. Since here the first mover earns more benefit, we can say that ThunderCo enjoys the first mover advantage.

12.4.2 Revisiting Battle of Sexes

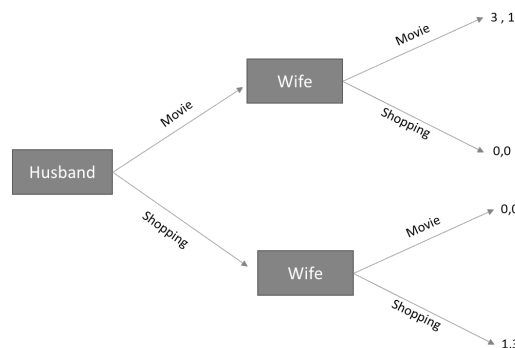
Let us re-consider the popular game called ‘Battle of sexes’ where a husband and wife can either go for movie or shopping together. Following is the payoff matrix that shows what each of them will receive because of their choices.

Figure 10:

		Wife	
		Movie	Shopping
Husband	Movie	3,1	0,0
	Shopping	0,0	1,3

Now imagine this game as a sequential game. This means that the husband (player 1) moves first and player 2 (wife) moves second. Try creating a game tree based on the information given above. You should place the husband on the initial node and then create two branches. Both branches will lead to the two decision nodes. We will then represent the Wife’s turn by creating two branches at each decision node. We will complete the game tree by stating the payoffs at the end of each terminal node. This is how your game tree should look like:

Figure 11:





Recall that we solve game trees using backward induction. This means that we will first analyze the strategy of player 2 and then move on to player 1. We have already established that both the players try to maximize their payoffs. In this example, the wife will prefer to go for a movie if the husband chooses to watch a movie, since she gets a payoff of 1 which is greater than 0, which would have been the case if she chooses to go shopping when her husband chooses to watch movie. Similarly, the wife will choose to go shopping if her husband also chooses to shop and gain a payoff of 3 instead of choosing to go for a movie and receive a payoff 0. You can clearly see that the wife gets maximum payoff when both of them go shopping, i.e., 3. Since the husband is aware of the payoffs and the choices that his wife will make in response to his actions, we now determine the husband's strategy. Once again, remember that the husband will select that strategy which gives him the maximum payoff. So, the husband already knows that if he chooses to go for a movie, his wife will also come along and watch a movie with him and if he chooses to go shopping, his wife too will choose shopping. But since the husband gets more payoff by watching a movie, he will choose the movie and his wife will not have any option than to accompany him. So, in a sequential game, we see that the Nash equilibrium is (Movie, Movie) with payoffs (3,1).

You may notice that here the husband, being the first mover, receives a higher payoff and hence we can say that the husband enjoys a first mover advantage.

IN TEXT QUESTIONS

6. Sequential game can be solved using
 - (a) Dominant strategy
 - (b) Backward induction
 - (c) Tit-for-tat
 - (d) None of these
7. The strategy of being the first to enter into the market may give the player a "first mover advantage." Explain whether the above statement is true or false.

12.5 SUMMARY

In this chapter we learnt about simultaneous and sequential game in detail and how to solve such games. We also distinguished between Nash equilibrium and dominant strategies. Nash equilibrium maximizes a player's payoff, and their choice depends upon what the other player is choosing. It is the strategic choice of each player, which provides no incentive to deviate from their initial strategy once chosen. So, it is the best choice of each player given the equilibrium strategy of other player. Whereas dominant strategy is the optimal choice of a player irrespective of what another player chooses. If dominant strategy exists, then Nash equilibrium will also exist but having a Nash equilibrium does not guarantee that a dominant strategy will also exist. Then we saw how in a sequential game, the player that moves first,



can influence the flow of the game in its own favor and hence enjoys a ‘first-mover advantage.’ The player that moves later has additional knowledge about the strategies of other players. Such a player can, therefore, make an informed choice.

12.6 GLOSSARY

Simultaneous games- A game where each player chooses their strategy at the same time, without knowing the strategy chosen by other players

Sequential games- A game where the players take turns to choose their strategies. The player that moves second has more information than the player that moves first

Nash equilibrium- The strategic choice of each player, given the equilibrium strategy of other player, which provides no incentive to deviate from their initial strategy once chosen

Dominant strategy- An optimal choice of strategy for each player, in which no matter what other player does, he will choose only his optimal strategy.

Prisoners’ dilemma- it is a game where player has two strategies – to cooperate or defect. Both players choose defect over cooperate whereas the outcome (defect, defect) is worse than the outcome of (cooperate, cooperate).

First mover advantage- A player enjoys a first-mover advantage if he achieves a higher pay off by being the first mover

12.7 ANSWERS TO IN-TEXT QUESTIONS

1. Player 1 is getting higher payoff when he chooses bottom because his payoff is higher i.e., 4 whereas in the case of top he gets only 2.
2. Two Nash Equilibria - (Wheat, Oat) and (Oat, Wheat) with payoffs (10, 10) for both Nash Equilibrium
3. False
4. False
5. A) Only one player – ‘Producers’ has a dominant strategy of High Quality
B) No dominant strategy
6. (B) Backward induction
7. True

12.8 SELF-ASSESSMENT QUESTIONS

Ques 1. Find all Nash equilibria of the following games:



a.

	<i>L</i>	<i>R</i>
<i>U</i>	2,4	1,3
<i>D</i>	3,1	5,3

b.

	<i>L</i>	<i>R</i>
<i>U</i>	-4,1	0,3
<i>D</i>	-2,1	4,0

c.

	<i>L</i>	<i>R</i>
<i>U</i>	2,2	3,3
<i>D</i>	3,1	-1,0

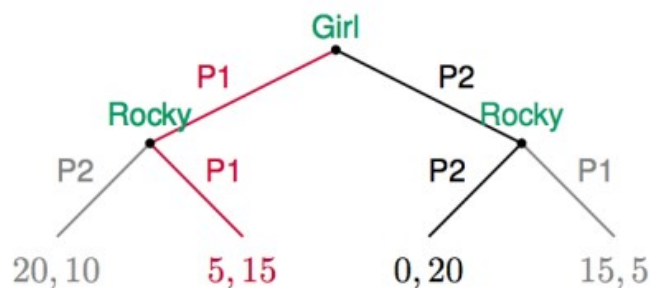
d.

	<i>L</i>	<i>R</i>
<i>U</i>	2,4	6,3
<i>D</i>	3,1	5,3

e.

		Incumbent	
		Share	Fight
Entrant	Enter	5,5	-1,1
	Don't	0,10	0,10

f.





Ques 2. Check whether the following statement is correct. Use an example to justify your answer.

“If dominant strategy exists then Nash equilibrium will also exist but having a Nash equilibrium does not guarantee that a dominant strategy will also exist”.

Ques 3. What do you mean by best response action?

Ques 4. Classify the following games into simultaneous or sequential games:

- i) The Cournot model of Duopoly.
- ii) The Bertrand model of duopoly.
- iii) The Stackelberg model of duopoly.

Ques 5. Two players – P and Q are playing a game in which Player one has two options to choose from – ‘up’ or ‘down’, whereas player two can choose from ‘left’ or ‘right.’ If Player one moves first and chooses ‘up’ and player two chooses ‘left’ then they receive (1,4). If Player one chooses ‘up’ and player two chooses ‘right’ then they receive (2,2). If player one chooses ‘down’ and player two chooses ‘left’ then they receive (1,2). If player one chooses ‘down’ and player two chooses ‘right’ then they receive (2,1). Solve this game using backward induction.

12.9 REFERENCES

- Acemoglu, D., Laibson, D., List, J. A. (2018). *Microeconomics*. New York: Pearson Education.
- Dixit, A. K., Skeath, S., & Reiley, D. H. (2015). *Games of Strategy* 4th ed. W. W. Norton & Company.
- Frank, R. H. (2015). *Microeconomics and Behavior*. New York: McGraw-Hill.

12.10 SUGGESTED READING

- Osborne, M. J. (2004). *An introduction to Game Theory* (Vol. 3, No. 3). New York: Oxford University press.



**Department of Distance and Continuing Education
University of Delhi**